

UNIDIR/2002/20

**The Scope and Implications
of a Tracing Mechanism
for Small Arms and Light Weapons**

UNIDIR
United Nations Institute for Disarmament Research
Geneva, Switzerland

and

SAS
Small Arms Survey
Geneva, Switzerland

NOTE

The designations employed and the presentation of the material in this publication do not imply the expression of any opinion whatsoever on the part of the Secretariat of the United Nations concerning the legal status of any country, territory, city or area, or of its authorities, or concerning the delimitation of its frontiers or boundaries.

*
* *

The views expressed in this paper are those of the authors and do not necessarily reflect the views of the United Nations Secretariat.

UNIDIR/2002/20

Copyright © United Nations, 2003
All rights reserved

UNITED NATIONS PUBLICATION

Sales No. GV.E.03.0.7

ISBN 92-9045-147-5

CONTENTS

	<i>Page</i>
Preface	vii
Acronyms	xi
Chapter 1	
Overview Paper	
Owen Greene	1
1.1 Introduction	1
1.2 Framing the Issues	2
1.3 Marking	8
1.4 Record-Keeping	14
1.5 Systems for SALW Tracing	18
1.6 Issues for the Scope and Implications of an International Tracing Mechanism for SALW	30
Bibliography	45
Chapter 2	
What to Mark and What to Trace? The Implications of Selecting Categories and Types of SALWs for Inclusion in a Tracing Mechanism	
Frédéric Schütz	47
2.1 What Are the Various Categories of SALW?	47
2.2 What Are the Controversial Aspects of the Categorization of SALW?	51
2.3 What Features of the Various Categories and Types Are Significant for a Tracing Mechanism?	54

2.4	What About Ammunition?	57
2.5	What Are the Criteria for Including or Excluding any of the Main Types of SALW?	61
2.6	Which SALW Should Be the Subject of a Tracing Mechanism? Why?	62
2.7	Do Any Categories or Types of SALW Require Special Types of Marking? If so, Which Ones and Why?	67
2.8	Are There Any SALW That Cannot Be Included in Any Type of Tracing Mechanism?	70
2.9	What Are the Implications of the Various Options?	74
2.10	High-Tech Versus Low-Tech Marking: Significant Implications for Tracing	76
2.11	How Could Difficulties Be Best Overcome?	78

Chapter 3

Marking and Record-keeping Systems and Modalities of Operation

	Michael Hallowes	89
3.1	The Different Kinds of Marking and Record-Keeping Systems Needed to Support a Tracing Mechanism	89
3.2	Existing National, Regional and Global Systems.	111
3.3	Gaps in Existing Controls Over the Legal Arms Trade	116
3.4	Building on Existing Practices	118
3.5	Lessons That Can Be Learned From Other Commercial Sectors	121
3.6	Storage and Access to the Information	125
3.7	Storage Mediums	127
3.8	Modalities for Communicating Information and Operating a Tracing Mechanism	127
3.9	Tracing Modalities	129
3.10	Initiating Tracing Requests	130
3.11	Appropriate Response Times	132
3.12	Establishing and Operating Cooperative Mechanisms	132
3.13	Confidentiality When Tracing Military Small Arms.	133
3.14	Legal Implications of Utilising Police and Military Tracing Mechanisms in an Arms Control Context	135
3.15	Conclusion	138

Chapter 4**Structures and Institutions Necessary to Support the Effective Operation of a Firearms Tracing Mechanism**

Gary L. Thomas	143
4.1 Fundamental Structures and Institutions	145
4.2 Existing Supporting Structures and Organizations	148
4.3 The Firearms Tracing “Players” and Their “Roles”	151
4.4 Low-, Middle- and High-Cost Options for Establishment of Effective Firearms Tracing System and Their Effectiveness	155
4.5 Conclusion	157

Chapter 5**Small Arms and Light Weapons Traceability: A Comparison of the Principal Existing International Mechanisms**

Michel Wéry and Ilhan Berkol.	161
5.1 Introduction	161
5.2 Comparison of the Principal Existing Mechanisms	163
5.3 Other Important Initiatives	185
5.4 Building a Mechanism that is Broader in Scope.	190
Bibliography	199

UNIDIR Publications	219
-------------------------------	-----

PREFACE

The illegal proliferation of small arms and light weapons is a global crisis. One consequence of the illicit trade in weapons is that regions become flooded with small arms before, during and following a violent conflict. After a conflict, guns often stay in the region, kept for personal security or for use in violent crime and the death and injury rate from the guns can remain extremely high in post-conflict societies. Even if peace and sustained development become rooted in a community and small arms and light weapons are traded in for more useful commodities, arms dealers often sell them on to people embroiled in a conflict in another part of the world. And so the vicious cycle begins again.

Practical measures have been introduced in many post-conflict situations to collect and destroy weapons so that they cannot be sold on to fuel violence elsewhere. However, large surplus stockpiles exist in some parts of the world, and new weapons are constantly being manufactured; many of these are diverted into the illegal markets, making their way into the hands of those who will use them to kill in conflict or in crime.

The world may be awash with a surplus of illegal weapons and although peacemakers may be draining hundreds of thousands out through weapons collection and destruction programmes, the tap of illegal diversion is still flowing.

One of the problems is that we do not know where, when and how legally manufactured weapons are being introduced into the illicit trade in small arms. Weapons that are collected following conflicts often yield few clues by themselves as to how they arrived and from where they most recently came. States that legally manufacture and sell small arms and light weapons thus have a clear interest in preventing diversion into the illicit trade, since they are often otherwise identified as the likely proliferators.

To prevent illicit diversion, one necessary (but not sufficient) measure is to mark weapons in an easily identifiable and coherent manner and to maintain databases of the production of marked weapons and their legal transfers, so that any illegally diverted weapons can be traced back to the

point of diversion, thus inhibiting illicit diversion for fear of subsequent exposure.

Whilst in theory such a measure may appear obvious, in practice it is far from trivial. Thousands upon thousands of weapons have to be so marked—and in such a way that the marks cannot be readily erased. More importantly, appropriate databases have to be maintained and access to those databases has to balance the need for information-sharing with concerns about commercial confidentiality. Different languages and different manufacturing traditions further complicate the whole process.

Despite these technical and practical obstacles, following the 2001 United Nations Conference on the Illicit Trade in Small Arms and Light Weapons in all its Aspects, the United Nations established a Group of Governmental Experts on Tracing Illicit Small Arms and Light Weapons, and the governments of France and Switzerland began a consultative process to prepare for future negotiations for an international instrument on tracing and marking of small arms and light weapons.

In order to assist these international efforts, the Small Arms Survey and UNIDIR undertook a technical study on the scope and implications of a tracing mechanism for small arms and light weapons.

The results of this technical study are contained in this report.

We are immensely grateful to the contributing authors: Ilhan Berkol, Owen Greene, Michael Hollowes, Frédéric Schütz, Gary Thomas and Michel Wéry, for their dedication and intellectual contributions to the study. Our gratitude goes to the governments of France and Switzerland for funding the study and to key individuals within the governments for their commitment and substantive contributions to the work. We thank Ambassador Rakesh Sood of India and Chair of the UN Expert group for his time and participation in discussions along with Nadia Fischer, Olivier Guerot, René Haug and Stefano Toscano. It must be said however that the opinions expressed in the papers are those of the authors and the authors alone.

Special thanks go also to our colleagues on the management team—Peter Batchelor and Christophe Carle—and to Glenn McDonald and Nicolas Florquin for their hard work in reading and editing and getting this

book into shape. Nicolas Gérard, Anita Blétry and Steve Tulliu took this book through to production and Isabelle Roger and Delphine Zinner carried out all the complicated administrative work.

We hope that this study will make a significant contribution to the literature on this topic and, more importantly, will have a tangible impact on reducing the number of illegal small arms and light weapons that are being used against innocent civilians in bloody wars all over the world. It is now up to governments to take this issue forward and make real what is demonstrably feasible.

Keith Krause
Small Arms Survey

Patricia Lewis
UNIDIR

Geneva December 2002

ACRONYMS

ATFUS	Bureau of Alcohol, Tobacco and Firearms
BATF	Bureau of Alcohol, Tobacco and Firearms (US)
BPA	British Proof Authorities
CFR	Canadian Firearms Register
CFR	Central Firearms Register
CICAD	Inter-American Drug Abuse Control Commission
CICAD	Model Regulations: Inter-American Drug Abuse Control Commission's Model Regulations for the Control of the International Movement of Firearms, their Parts and Components, and Ammunition
CIP	Commission of International Proof
DDPS	Federal Department of Defence, Civilian Protection, and Sports(Switzerland)
DRC	Democratic Republic of Congo
EAPC	Euro-Atlantic Partnership Council
ECOWAS	Economic Community of West African States
EU	European Union
FN	Fabrique nationale
FREDES	Firearms Registration Direct Entry System
FRT	Firearms Reference Table
GRIP	Group de recherche et d'information sur la paix et la sécurité (Brussels)
IWETS	Interpol International Weapons and Explosives Tracking System
NATO	North Atlantic Treaty Organisation
NCB	National Central Bureau (of each national member of Interpol)
NCIS	National Criminal Intelligence Service (UK)
NFFID	National Firearms Forensics Intelligence Database (UK)
NFTS	National Firearms Tracing Service (UK)
NGO	Non-Governmental Organization
NTC	National Tracing Centre (USA)

OAS	Organization of American States
OASConvention	Inter-American Convention against the Illicit Manufacturing of and trafficking in Firearms, Ammunition, Explosives, and other Related Materials
OSCE	Organisation for Security and Co-operation in Europe
OSCE	Document: OSCE Document on Small Arms and Light Weapons
PGT	Pretty good tracing
PT	Perfect tracing
RCMP	Royal Canadian Mounted Police
SADC	Southern Africa Development Co-operation
SADC	Protocol: Southern Africa Development Co-operation, Protocol on the Control of Firearms, Ammunition and Other Related Materials
SALSA	Small Arms and Light Weapons Administration software system of registration and record-keeping (based at UNLiREC)
SALW	Small arms and light weapons
SANDF	South African National Defence Force
SAS	Small Arms Survey
UN	United Nations
UN Firearms Protocol	Protocol against the illicit manufacturing of and trafficking in firearms, their parts and components and ammunition, supplementing the United Nations Convention against Transnational Organized Crime
UN Programme of Action	UN Programme of Action to Prevent, Combat and Eradicate the Illicit Trade in Small Arms and Light Weapons in All Its Aspects
UN FP	UN Firearms Protocol
UNIDIR	United Nations Institute for Disarmament Research
UNLiREC	United Nations Regional Centre for Peace, Disarmament and Development in Latin America and the Caribbean
UN TOC	UN Transnational Organised Crime Convention

VIN	Vehicle Identification Number
WFSA	World Forum on the Future of Sport Shooting Activities
WIES	Weapons Information Exchange System
WR	Wapen Register

CHAPTER 1

OVERVIEW PAPER

Owen Greene

1.1 INTRODUCTION

This paper highlights many of the key findings of a study on the scope and implications of developing a tracing mechanism for small arms and light weapons (SALW). Conducted by a group of international experts convened by UNIDIR and SAS,¹ this overview paper draws upon the four detailed technical papers produced as part of the study,² and upon the discussions of the Study Group. Although responsibility for its contents rests with the author alone, it aims to reflect the discussion among Study Group members.

There is now broad agreement that efforts to combat the illicit trafficking and proliferation of SALW are obstructed by inadequate capacity to trace the sources and lines of supply of illicit arms. Tracing requires adequate marking and record-keeping of all SALW, along with international cooperation to enable relevant authorities to trace sources, supply routes and diversion points of illicit weapons. At present, there are substantial problems in each of these areas, which need to be systematically and effectively addressed.

A wide range of initiatives have been developed in recent years at the national, regional and international levels for the purpose of tackling the small arms problem. Most prominently, in July 2001, States agreed a *Programme of Action to Prevent, Combat and Eradicate the Illicit Trade in Small Arms and Light Weapons in All Its Aspects*.³

The illicit trafficking and proliferation of SALW is an immensely complex and multifaceted issue. Systems to ensure traceability of sources

and lines of supply of illicit SALW are therefore no panacea, but can be just one element of the comprehensive set of programmes and measures needed for effective international action. Nevertheless, based on the information presented in this overview paper (and the broader study on which it draws) it is clear that systems to ensure the traceability of sources and lines of supply of illicit SALW are not only feasible but also have an essential contribution to make in the overall effort to tackle this global problem.

1.2 FRAMING THE ISSUES

1.2.1 Small Arms and Light Weapons: Defining the Weapons of Concern

This study is concerned with tracing mechanisms for small arms and light weapons. Broadly speaking, small arms are those weapons designed for personal use, while light weapons are those intended for use by several persons acting as a crew.

There is as yet no agreed international definition of SALW. Most widely used is that proposed by the UN Panel of Governmental Experts on Small Arms in its 1997 report.⁴ According to the Panel, the category of small arms includes revolvers and self-loading pistols, rifles and carbines, sub-machine guns, assault rifles and light machine guns. Light weapons include heavy machine guns, hand-held under-barrel and mounted grenade launchers, portable anti-aircraft guns, portable anti-tank guns, recoilless rifles, portable launchers of anti-tank missile and rocket systems, portable launchers of anti-aircraft missile systems, and mortars of calibres of less than 100mm. There is thus a large overlap between the category of SALW and that of a “firearm”, widely defined as any portable barrelled weapon that expels a shot, bullet or projectile by the action of an explosive.

Although most governments and analysts now use this relatively broad UN description of SALW, there are continuing disagreements over details. For example, numerous governments are reluctant to consider ammunition and explosives as part of SALW, though UN expert groups, beginning with the 1997 Panel, have consistently included them.

Ammunition and explosives are included within the scope of the present study, along with weapons parts and components. These are often inseparable from other types of SALW in conflict and crime settings. In principle and in practice, the need to trace the origins and lines of supply of illicit ammunition and explosives is as great as for the weapons themselves. However, this does not necessarily imply that detailed marking and record-keeping practices and standards, for example, should be the same for ammunition and explosives as for the weapons. This is clearly not the case at present, and seems unlikely for the foreseeable future as well.

The category of SALW encompasses a wide range of weapons, even if ammunition and explosives are not taken into account. Different types of SALW tend to be more closely associated with particular crimes or problems than others, depending on the region, and are often trafficked through distinct mechanisms and routes. Different sub-categories of SALW also pose specific challenges for marking, record-keeping and tracing. Effective tracing, for example, will often make extensive use of information extrinsic to the weapon, such as the circumstances in which it was seized, as well as of marks on the weapon itself.⁵

That said, it appears that definitions of SALW matter little to the issue with which this study is primarily concerned—clarifying possibilities for developing international standards and mechanisms for the effective tracing of SALW. Law enforcement agencies and other relevant authorities should generally be able to trace the illicit weapons, which they seize, irrespective of exact definitions.

1.2.2 Tracing Small Arms and Light Weapons

The tracing of illicit SALW is the systematic process of tracking the history of one or more weapons (or associated components or ammunition) that have been discovered or seized—from their source (the manufacturer or last legal importer), through the lines of supply, to the point at which they were diverted into the illicit market, and hopefully ultimately to the person or group that last possessed it. This tracing process will normally involve examining existing records of legal possession and transfers, but often also requires investigations involving personal interviews and other contacts.

There are two main reasons for tracing an illicit weapon.

First, if a weapon has been involved in a crime, or found in the illicit or unauthorized possession of a person or group, the relevant authorities have every incentive to trace the weapon as part of their investigation to prosecute those involved and (where the weapon has been illicitly supplied) to identify, prosecute or close down the operations of those involved in trafficking the weapon.

Second, if illicit or unauthorized weapons are seized or found, relevant authorities may wish to trace illicit weapons in order to discover and monitor lines of supply, and identify possible traffickers and points of diversion from the legal sphere, and thus enable actions to disrupt future supplies of illicit arms. Consequent action to disrupt future supply may target arms sources and trafficking routes feeding organized criminal groups, terrorists, rebel groups, and regions of war and instability.

Comprehensive tracing of such weapons, combined with analysis, can enable law enforcement agencies and other relevant authorities to identify and monitor trends and patterns of supply and use of illicit arms, and thereby help them to focus their resources effectively to combat, prevent and reduce such problems.

Other important applications of tracing include the following:

- identifying and preventing losses from military and other official or authorized arms stocks;
- identifying lines of supply of arms to countries/organizations subject to UN or other arms embargoes, in order to combat and prevent sanctions breaking activities.

In some ways, all of these contexts are similar. They all aim to combat, prevent and reduce illicit flows and accumulations of arms and ammunition. Moreover, these settings all tend to have an important regional or international dimension. Sources of illicit weapons may be in neighbouring countries or on other continents. Lines of supply will often be long and complex, involving a series of legal as well as “grey” or “black” market transactions. This makes regional and international cooperation crucial for effective tracing.

Yet, despite the similarities, there are important institutional and political differences in these various settings. Police and associated civilian

law enforcement agencies generally regard investigations of losses from military stockpiles, illicit arms trafficking to zones of armed conflict, or arms embargo breaking activities to be outside their area of competence and authority. Armed forces tend to have their own agencies and authorities that are responsible for their arms stocks, and for investigating and preventing possible losses or misuse. Efforts to trace and disrupt international flows of illicit arms to countries in conflict or under UN embargo may be politically sensitive, and will often concern national arms transfer licensing authorities and government departments dealing with issues of national and international security. If tracing systems are to work effectively, they need to be designed so that relevant authorities can cooperate fully in each of these contexts.

An effective system to enable tracing of SALW requires three key elements:

- adequate marking of SALW, so that each item can be uniquely identified from its marks;
- adequate record-keeping, so that reliable and readily accessible records are maintained for each item at every key stage of its existence, beginning with manufacture;
- mechanisms and arrangements to enable relevant authorities to use the marks and records to trace the origins and lines of supply of illicit weapons (including components and ammunition) in a timely and reliable manner.

While extensive systems already exist for the marking, record-keeping and tracing of SALW, substantial problems need to be addressed in each of these areas. These are discussed in the following sections of this paper and, in more detail, in the associated technical studies.

1.2.3 International Frameworks for Enhancing Marking, Record-Keeping and Tracing of SALW

Most tracing activities are currently conducted within the country in which the illicit weapons have been seized, even though, as noted above, many illicit arms originate outside the country. Here we briefly introduce the key global and regional initiatives relating to marking, record-keeping and tracing of SALW in order to clarify the frameworks that are developing for international cooperation.

The UN Programme of Action includes a number of substantial politically-binding commitments to ensure adequate marking, record-keeping and cooperation in tracing of SALW.⁶ Prominent among these is a commitment “to strengthen the ability of States to cooperate in identifying and tracing in a timely and reliable manner illicit small arms and light weapons” (Section II, paragraph 36). The Programme also calls on the UN to examine the feasibility of developing an international tracing instrument for illicit SALW (Section IV, paragraph 1c). A UN Group of Governmental Experts has been established for this purpose and will report to the UN Secretary-General by August 2003, in time for consideration by the General Assembly at its 58th session.

At the regional level, several recent agreements include commitments to enhance cooperation in tracing, including the OSCE Document on Small Arms and Light Weapons and the SADC Protocol.⁷ A number of governments are also considering how to enhance their cooperation in tracing illicit SALW, building on the ideas contained in the French-Swiss initiative launched in 2000.⁸

These initiatives are all concerned with the illicit manufacture, transfer and circulation of SALW *in all its aspects*, including that which contributes to the excessive accumulation and uncontrolled spread of SALW in many regions of the world, and which sustains and intensifies armed conflicts. They are complemented by international agreements with a different focus, which are primarily concerned with crime prevention and criminal justice.

The OAS Convention,⁹ in force since July 1998 and reinforced by the CICAD Model Regulations,¹⁰ is the most significant regional agreement of the latter kind. At the global level, the most important agreement of this type is the UN Firearms Protocol.¹¹ This legally-binding Protocol was agreed in March 2001 and will enter into force once ratified by 40 States. It aims “to promote, facilitate and strengthen cooperation among States Parties in order to prevent, combat and eradicate the illicit manufacturing of and trafficking in firearms, their parts and components and ammunition” (Article 2).

Implementation of the UN Firearms Protocol will significantly enhance international cooperation in tracing illicit firearms, their parts and components and ammunition. Articles 7 and 8 set out important minimum standards for record-keeping and marking, while Article 12 (paragraph 4)

commits States parties to cooperate in the tracing of illicit firearms, and in providing prompt responses to requests for tracing assistance. The definition of a “firearm” in the Protocol is quite broad: “any portable barrelled weapon that expels, is designed to expel or may be readily converted to expel a shot, bullet or projectile by the action of an explosive, excluding antique firearms or their replicas” (Article 3 a.). In practice, the Protocol thus covers many types of small arms and light weapons.

The Firearms Protocol is primarily concerned with “offences [which] are transnational in nature and involve an organized criminal group” (Article 4.1). It does expressly exclude from its scope “State-to-State transactions or State transfers in cases where the application of the Protocol would prejudice the right of a State Party to take action in the interest of national security consistent with the Charter of the United Nations” (Article 4.2).

The scope of the UN Firearms Protocol was subject to intense negotiations, and the resulting agreement is quite broad in scope. But the limits suggest that at least some States parties might regard attempts to use the UN Firearms Protocol to trace flows of illicit arms to areas of armed conflict or to countries subject to UN arms embargo to be beyond the scope of the agreement, particularly if the lines of supply involved State-to-State transfers at some stage. For this reason, tracing mechanisms derived from the relatively broader UN Programme of Action also appear to be needed.

Other international agreements and standards exist for the marking and tracing of ammunition and explosives.¹² These include the Convention on Marking Plastic Explosives (in force since 1998), which establishes important standards to enable tracing of plastic explosives that may be used by terrorists, and international regulations for the transport of dangerous materials, developed on the basis of the 1996 UN Model Regulations.

As the present study indicates, there is substantial experience with systems for marking, record-keeping and tracing of illicit SALW. Moreover, there are also many opportunities to greatly improve existing practices and systems. It is obviously important to be realistic about priorities for any international agreement. There is a difference between identifying and encouraging best practices at a national level, and establishing and implementing internationally-agreed systems and standards at a global level. The following sections aim to identify opportunities and priorities in both contexts.

1.3 MARKING

1.3.1 Introduction

A wide range of consumer goods—including automobile parts, computers, electrical equipment and toys—are marked with a serial number or other unique code at the time of manufacture, in order to permit their identification and, if necessary, tracing. So it is with most SALW. The majority of small arms manufacturers mark the weapons they produce with a serial number and other identifying marks during the production process. Virtually every arms producing country has some form of regulation of the manufacture and marking of weapons produced within its jurisdiction. However, regulatory requirements and marking practices vary widely and are often inadequate. For example, marks may not be unique or may be easy to remove or difficult to read. Unmarked or inadequately marked batches of weapons continue to be produced—often for the home country's armed forces.¹³

1.3.2 Methods for Marking SALW

As mentioned, most SALW are marked during manufacture. Using a variety of marking techniques including engraving, casting, stamping and etching, marks are applied to such essential weapon components as the frame and receiver. In practice, the location of marks varies widely, depending on the manufacturer and relevant national regulations.

Most—but not all—arms manufacturing States require the primary identifying marks to be conspicuous, permanent and legible if the weapons are intended for the civilian market. However, manufacturers do not always uniquely mark the weapons they make for national armed forces, leaving the armed forces to mark such arms later, according to their own needs.

Worldwide, the preferred method for marking SALW remains stamping (impressing) on the metal. This is not only simple and cheap, but also has substantial forensic advantages. The depth of disruption to the molecular structure of metal caused by stamping is much greater than with less intrusive methods, such as etching and engraving—thus improving the chances of retrieving information even after attempts are made to erase the mark.

It is, in fact, important that marks cannot be easily obliterated, altered or removed. Those who hold and trade weapons, such as handguns, for criminal purposes have a strong interest in disguising their sources of (often legal) supply, particularly if they are sourced reasonably directly from a supplier such as a dishonest registered firearms dealer. Criminals will therefore try to remove or obliterate identifying marks, for example by grinding, drilling or gouging them away with metal working tools. Where successful, this process is known as “sanitization”.¹⁴

Attempts to sanitize illicit SALW have, to date, been less common in conflict zones, where there has been less likelihood of tracing attempts and in any case the lines of supply are typically complex, with extensive recirculation among armed groups. Nevertheless, it appears that increased efforts to trace illicit arms in conflict zones have prompted an increase in sanitization efforts.¹⁵

It is therefore important to sustain, indeed intensify, efforts to make sanitization more difficult. For example, US regulations specify a minimum depth of 0.003 inches and a height of 1/16th inch for all firearm serial numbers. Manufacturers can place marks in less visible or accessible components of the weapons, or on delicate but essential components that would be damaged by attempts to remove marks. Marks may also be stamped on two or more locations of the same component in order to facilitate the retrieval of erased information.

It is in this context that the concept of covert secondary marking has developed. This has been facilitated through the use of less traditional marking techniques, including laser etching, embedded electronic chips, and the mixing of chemical tracers in materials from which weapons parts are constructed. These can be used to make “back-up” marks that may prove essential to the future identification of the weapon. Laser etching, for example, can engrave detailed information in an area so small it will usually escape the notice of those attempting to sanitize the weapon.

Techniques also exist for marking ammunition and explosives. Cartridges (rounds) for small arms are generally marked by head stamping, although this information generally identifies the batch, as opposed to individual rounds. Practices vary widely with more complex forms of ammunition, such as shells and missiles. Explosives can most easily be marked during manufacture with the use of chemical tracers, which

uniquely identify each production batch. This technique is now widely used during the manufacture of plastic explosives, but remains exceptional with the types of explosives used in ammunition.

Many countries require that imported SALW also be marked with the ordnance mark for that country, along with the year of importation, or—in the case of civilian firearms—with the importer’s name and address or logo. The thirteen countries¹⁶ that are members of the Commission of International Proof (CIP) have agreed regulations requiring all firearms and military small arms to be safety tested and stamped with verification marks (including a national stamp and year code) prior to use, sale or export.

1.3.3 The Content of Markings

There are three main approaches to the marking of content on SALW.¹⁷ The first involves putting all of the required information in a single code of letter and numbers (full alphanumeric code).¹⁸ Such codes are easy to read and reproduce and provide unique identification of the weapon without reading any further information from the weapon.

The second approach, used by China, Russia and many former Soviet bloc countries, combines alphanumeric code with symbols (for example, of an individual factory) to enable unique identification.¹⁹ The effectiveness of this system is undermined by the fact that officials from other countries may miss the significance of the symbol or misinterpret it, and are prone to mis-copy it in record-keeping or tracing communications.

The third approach, used for example by the US, is to combine an alphanumeric code or serial number with other identifiers on the weapon denoting manufacturer, model and calibre for unique identification of the weapon. Combining all of this information provides unique identification, but officials unfamiliar with such a system may be confused about which marks on the weapon are required for identification.

Most SALW also have a number of marks in addition to those comprising the unique identifier. These include proof marks, import marks, importers’ marks, armourers’ marks, selector markings and a range of other indicators that experts can use as supplementary information to help them identify an individual weapon, especially if the serial numbers or identifying

codes have been sanitized. Although these tend not to be individually unique, in combination they can allow the history and likely source of the weapon to be traced.²⁰

Weapons components and spare parts may or may not be marked. In many countries, components that are prone to wear and may be regularly replaced are not uniquely marked. Lack of such marks can help reduce confusion, as attention remains focused on the markings contained on the permanent components. However, it also means that a high degree of specialist knowledge is generally required to identify component parts when they are separated from the complete weapon.

1.3.4 Emerging International Norms and Good Practices

The establishment of international norms and minimum standards for the marking of firearms and SALW has been a prime concern in recent years, with most effort channelled into the adoption, in 2001, of both the UN Firearms Protocol and the UN Programme of Action. Several important regional agreements, with substantial provision for marking, have recently been agreed and will also be described here.²¹

The UN Firearms Protocol

Article 8 of the UN Firearms Protocol states that States parties shall:

- At the time of manufacture of each firearm, either require unique marking providing the name of the manufacturer, the country or place of manufacture, and the serial number, or maintain any alternative unique user-friendly marking with simple geometric symbols in combination with a numeric and/or alphanumeric code, permitting ready identification by all States of the country of manufacture (Article 8, paragraph 1 a);
- Require appropriate simple marking on each imported firearm, permitting identification of the country of import and, where possible, the year of import and enabling the competent authorities of that country to trace the firearm, and a unique marking, if the firearms does not bear such a marking (Article 8, paragraph 1 b);

- Ensure, at the time of transfer of a firearm from government stocks to permanent civilian use, the appropriate unique marking permitting identification by all States parties of the transferring country (Article 8, paragraph 1 c)
- Encourage the firearms manufacturing industry to develop measures against the removal or alteration of markings (Article 8, paragraph 2).

One of the most difficult issues addressed during negotiations on the Protocol was whether to allow the use of geometric symbols. The agreement achieved, reflected in paragraph 1a, may well define the global minimum standard on firearms marking for some years to come, even though many countries and regions decide to exceed them.

The UN Programme of Action

The UN Programme of Action, agreed three months after the UN Firearms Protocol, includes consistent and similar commitments on marking. Participating States agreed to:

- Ensure that henceforth licensed manufacturers apply an appropriate and reliable marking on each small arm and light weapon as an integral part of the production process. This marking should be unique and should identify the country of manufacture and also provide information that enables the national authorities of that country to identify the manufacturer and serial number, so that the authorities concerned can identify and trace each weapon (Chapter II, paragraph 7);
- Adopt where they do not exist and enforce, all the necessary measures to prevent the manufacture, stockpiling, transfer and possession of any unmarked or inadequately marked small arms and light weapons (Chapter II, paragraph 8);

Participating States were further encouraged to:

- Exchange information on a voluntary basis on their national marking systems on small arms and light weapons (Chapter III, paragraph 12).

Regional Agreements

The three regional agreements discussed in section 1.2.3 have similar provisions for marking. As in the UN Firearms Protocol, Article VI of the OAS Convention requires marking at the time of manufacture and import. Moreover, it requires, in addition to firearms, that “any other weapon or destructive device such as any explosive, incendiary or gas bomb, grenade, rocket launcher, missile, missile system or mine should be marked appropriately at the time of manufacture, if possible” (Article VI, paragraph 2).

The marking obligations of the SADC Protocol are quite similar to those of the UN Firearms protocol, though the number and location of marks are specified in greater detail. “States Parties undertake to establish agreed systems to ensure that all firearms are marked with a unique number, at the time of manufacture or import, on the barrel, frame and, where applicable, the slide” (Article 9.1).

The OSCE Document goes beyond the marking requirements of the UN Firearms Protocol, specifying that marks at the time of manufacture should permit identification of the year of manufacture. Along the same lines as the UN Programme of Action, OSCE States also committed themselves to ensure that “should any unmarked small arms be discovered in the course of the routine management of their current stockpiles, they will destroy them, or if those small arms are brought into service or exported, that they will mark them beforehand with an identifying mark unique to each small arm” (Section II, B.2).

The UN Programme of Action and the UN Firearms Protocol, taken together, establish a set of global minimum standards for the marking of SALW. However, these fall short of what is increasingly recognized as good practice. For example, the use of geometric symbols in identification marks—in addition to alphanumeric—makes international identification of such weapons and tracing cooperation more difficult.²² Some of the regional obligations noted above could usefully be adopted globally, including a commitment to destroy or appropriately mark any inadequately marked arms found in existing stockpiles.²³

Other opportunities for improved international standards on marking exist in the following areas:

- increasing the resistance of marks to attempts at sanitization, for example through the use of multiple marks or covert secondary marking techniques;
- developing requirements to uniquely mark key parts and components;
- developing requirements to uniquely mark other types of weapons within the category of SALW beyond small arms and firearms, including light weapons such as missiles and launchers;
- requiring marking for ammunition and explosives (as is at least encouraged in the OAS Convention).

These are all areas where it is possible to identify and encourage good practice. To cite just one example, the use of chemical marking agents in plastic explosives, described earlier, could be explored for purposes of marking ammunition and explosives generally.²⁴

1.4 RECORD-KEEPING

1.4.1 Introduction

Ensuring adequate, unique, marking of SALW is of little value unless measures are also taken to ensure that adequate and accessible records are systematically maintained for each marked weapon, that record such key elements of its history as production, distribution, resale and transfer. Weapons traces are largely conducted by referring to such records and associated databases.²⁵

1.4.2 Existing Record-Keeping Practices

Record-keeping systems for SALW vary enormously across the world, depending on national traditions, laws and government structures. In most countries, records are quite decentralized. Databases concerning military weapons destined for export or held by the armed forces are generally maintained separately from those relating to civilians. Much of the data needed to identify manufactured arms, components or ammunition is held by manufacturers, while commercial dealers hold information on distribution and resale. Data relating to the international transfer of SALW will mostly be held by customs or border control authorities, national arms transfer licensing authorities, and by the various exporters and importers involved.

In many countries, including the US and Switzerland, constitutional or other legal constraints preclude the centralization of civilian firearms ownership and transaction records at the national level. Yet, even in the majority of countries facing no such restrictions, record-keeping tends to be decentralized, with records held by a wide range of national, regional and local authorities, manufacturers and commercial arms dealers.²⁶

Whatever the system, States need to ensure that all relevant record-holders maintain, retain and ensure timely access to all necessary records. Although stakeholders, such as manufacturers and commercial dealers, normally have an interest in maintaining records of their dealings, most governments recognize that their commercial interest in keeping the full records required for reliable tracing may be more limited. Informal understandings and industry “codes of conduct” on record-keeping are therefore bolstered by governments through appropriate laws, regulations or licensing regimes. In addition to ensuring that adequate records are maintained, these give law enforcement officers authority to access records in a timely and reliable fashion for purposes of weapons tracing. Some, but unfortunately not all, States also require manufacturers or dealers going out of business to surrender their weapons records to governmental authorities.²⁷

In practice, problems with record-keeping systems are widespread. Many developing and transitional countries, as well as some developed countries, lack the systems needed to ensure that necessary records are maintained and can be rapidly accessed. Many databases are also paper-based, resulting in significant delays in responses to tracing requests.

Access to computers and effective software is improving across the world, making it feasible for many developing and transitional countries to move towards electronic database systems. However, although effective software packages are increasingly available, considerable resources are still needed to set up effective electronic systems with appropriate links and remote access, and to convert existing paper records into electronic form.

1.4.3 Emerging International Norms and Good Practices

As with standards in marking, there has been significant progress in recent years towards establishing regional and international norms and standards for adequate record-keeping for SALW.

The UN Firearms Protocol, in its Article 7, requires that:

Each State Party shall ensure the maintenance, for not less than ten years, of information in relation to firearms and, where appropriate and feasible, their parts and components and ammunition that is necessary to trace and identify those firearms and, where appropriate and feasible, their parts and components and ammunition which are illicitly manufactured or trafficked and to prevent and detect such activities. Such information shall include:

- a) The appropriate markings required by article 8 of this protocol (see section 1.3.4, above);
- b) In cases involving international transactions in firearms, their parts and components and ammunition, the issuance and expiration dates of the appropriate licences or authorizations, the country of export, the country of import, the transit countries, where appropriate, and the final recipient and the description and quantity of the articles (article 7).

Similarly, in the UN Programme of Action, participating States undertake to:

ensure that comprehensive and accurate records are kept for as long as possible on the manufacture, holding and transfer of SALW under their jurisdiction. These records should be organized and maintained in such a way as to ensure that accurate information can be promptly retrieved and collated by competent national authorities' (Section II, paragraph 9).

It is important to note that these obligations are framed so that States have broad discretion in the legal and practical organization of record-keeping. Whatever the theoretical attractions, global level measures for the harmonization and centralization of record-keeping are impractical given the wide variations in existing national systems.²⁸

The OAS Convention and the OSCE Document share many of the features, and weaknesses, of the global record-keeping obligations outlined above. However, OSCE States, *inter alia*, explicitly commit themselves to maintaining adequate records for effective military stockpile management and security (Article IV. B. I), while the SADC Protocol contains relatively stringent and precise obligations on firearm record-keeping. Specifically, States parties undertake to:

- keep proper record of the markings (Article 9.1);

-
- establish and maintain complete national inventories of firearms, ammunition and other related materials held by security forces and other State bodies (Article 8.a);
 - incorporate as a matter of priority in their national laws the regulation and centralized registration of all civilian owned firearms in their territories (Article 5.3);
 - consider a coordinated review of national procedures and criteria for issuing and withdrawing of firearm licenses and establishing and maintaining national electronic data-bases of licensed firearms, firearm owners, and commercial firearms traders within their territories (Article 7);
 - improve the capacity of police, customs, border guards, the military, the judiciary and other relevant agencies to establish and improve national data-bases (Article 6.b);
 - establish national firearms databases to facilitate the exchange of information on firearms imports, exports and transfers (Article 16.b).

SADC States have thus committed themselves to substantially strengthening registration, record-keeping and information exchange systems for SALW. Currently, only Namibia and South Africa have electronic record-keeping systems, with other countries in the region relying on the manual, paper-based variety. However, the new central Firearms Register developed by South Africa has been designed so that other countries in Southern Africa can use it as well.²⁹

Regional cooperation of this kind is not unique. Two important initiatives are now underway in the Americas, involving the Organization of American States (OAS), the Inter-American Drug Abuse Control Commission (CICAD), and the UN Regional Centre for Peace, Disarmament and Development in Latin America and the Caribbean in Lima (UNLiREC). The first builds on an OAS General Assembly resolution to counter the proliferation and illicit trafficking in SALW,³⁰ and involves the development of harmonized national legislation and regulations throughout the OAS region. The Royal Canadian Mounted Police (RCMP) has provided software for an Internet-based system of registration and record-keeping called SALSA (Small Arms and Light Weapons Administration).³¹ Weapons dealers will be required to register with SALSA and, once authorized, will be able to record details of individual weapons transfers on-line via secure Internet channels. The second initiative is the establishment of a "Regional Clearing-House Project on Firearms, Ammunition and Explosives". One

component of this project is to identify and record details of seized illicit weapons caches prior to their destruction, and then use such information in tracing sources of illicit supply.

Similarly, in 1991, the member States of the EU agreed to introduce a harmonized system to license the movement of firearms and ammunition between them.³² As a supporting measure, they established the Weapons Information Exchange System (WIES) in order to share information about sales and transfers of firearms and ammunition within the EU. Surprisingly, however, this system remains entirely paper driven and reliant on the exchange of faxes, which are rarely translated into the language of the receiving State. It is therefore relatively ineffective.

Initiatives to develop coordinated and linked databases at the regional level, such as those described in southern Africa, the Americas and the EU, are becoming recognized as good practice and need further assistance and encouragement.

Some important global norms have therefore been established in relation to record-keeping for SALW. Yet they have significant weaknesses. For example, a commitment to maintain records for “at least ten years” is plainly unsatisfactory in view of the typical lifetimes of several decades of small arms. In this context, the emerging international norm that such records should be maintained “for as long as possible” is also problematic and vague. There is little practical reason why records should not be maintained indefinitely, particularly as computerization gains ground. Commitments to ensure effective management of military stocks need to be developed to global standards requiring reliable inventories of official stocks. Moreover, international practices and norms remain inadequate with respect to record-keeping for parts, components, ammunition and explosives, with most regions so far unable to agree on effective standards in these areas.

1.5 SYSTEMS FOR SALW TRACING

1.5.1 Introduction

At its core, a tracing system is an identification, data collection and retrieval system. Information about weapons, such as their serial number

and other identifiers and history, is collected and retained in databases. This then needs to be retrieved in a reliable and timely fashion.

Much weapons tracing is carried out domestically, tracing sources and lines of supply within the country concerned. But many illicit arms arrive through transnational trafficking routes, making international tracing cooperation essential. In the UN Programme of Action, the UN Firearms Protocol, and numerous regional agreements, participating States have committed themselves to cooperate in tracing illicit SALW, and to strengthen their capacity to do so.

Weapons tracing is perhaps most regularly and intensively carried out for purposes of law enforcement and crime prevention. Yet, tracing is also carried out to investigate, prevent or disrupt: losses from military and other official stocks; illicit trafficking to terrorists, rebel groups and war zones; and attempts to break arms embargoes.

Tracing involves a number of key steps:³³

- correctly identify the weapon (or component or ammunition);
- establish the legal status of the weapon (legal, illicit?);
- determine the source and line of supply of the weapon by identifying its manufacturer or importer and tracing its subsequent history; and
- identify the point of its diversion from the legal sphere.

In police and other investigations, the process often continues, as follows:

- determine, where possible, the chain of possession since diversion;
- determine the possible criminal use of the weapon before or after diversion; and
- reassess the evidential value of the weapon in a criminal investigation.

1.5.2 Systems for Weapons Tracing by Law Enforcement Agencies

Any system for weapons tracing must be based on a framework of laws, regulations and law enforcement structures governing the manufacture, transfer and record-keeping of arms and their parts, components and ammunition. Such laws establish whether particular weapons can be legally held, and the conditions for their manufacture, possession, use and sale.

They clarify whether a weapon is illicitly supplied or held, and provide the context in which the police may initiate a trace. Good law minimizes ambiguity: if a weapon is not legal, it should be illegal.

Cooperation with industry is in practice a critical element of an effective tracing system. In States with a significant commercial firearms industry, manufacturers and dealers not only help to ensure adequate and unique marking and effective record-keeping, but are also an important repository of expertise.³⁴ The same can be said of military and State-controlled arms factories and institutions. A bewildering array of models, types and variants of weapons, components and ammunition has been produced during the past hundred years. A successful tracing system can require substantial expertise in identifying such weapons. Working links to the arms industry are essential as it employs many of the most prominent experts.

Firearms tracing for law enforcement purposes has a long history, and a variety of supporting institutions have evolved to support it. These include individual State institutions, as well as commercial, regional and international organizations.

Tracing capabilities vary widely among countries. The US has developed one of the most extensive systems, not least because of the vast number of firearms owned by US citizens and because of the country's importance as a world producer. Operating under the jurisdiction of the US Bureau of Alcohol, Tobacco and Firearms (ATF), the National Tracing Center (NTC) operates around the clock and accepts trace requests from throughout the world for US source crime guns, including firearms that have either been manufactured in the US or legally imported. The NTC maintains data on stolen firearms, firearms with obliterated serial numbers, firearms which are thought to have been trafficked but have not yet been recovered in crime, and suspicious multiple sales of firearms to the same individual. It also keeps more than 300 million individual transaction records from out-of-business dealers. ATF estimates that it traces about 240,000 firearms each year.³⁵

National tracing centres, such as NTC, also play an important role in encouraging and facilitating more systematic weapons tracing activities at the local or State/provincial level.³⁶ ATF also demonstrates the value of systematic cooperation between national weapons tracing authorities and

industry and trade groups. ATF is electronically linked via computer to several of the main firearms producers in the US, permitting virtually instantaneous access on a 24-hour basis to important trace information.

Many other countries also have substantial national resources for tracing. In the UK, police can make use of the National Firearms Tracing Service (NFTS), based at the National Criminal Intelligence Service (NCIS). In Canada, the RCMP has developed substantial resources including a photographic database to assist with firearms identification, known as the Firearms Reference Table (FRT). This catalogues over 22,000 types of firearms and SALW, and is regularly updated. Police can gain remote access to this system through secure Internet channels, enabling them to make on-line comparisons between the weapons they are examining and the FRT catalogue.³⁷

The FRT is currently being upgraded and incorporated into the Interpol International Weapons and Explosives Tracking System (IWETS), enabling on-line access from the Regional and National Central Bureaus (NCBs) of all Interpol members. The RCMP are also making the FRT catalogues available to OAS member countries, through the Regional Clearing-House Project discussed in section 1.4. These examples show how information technology allows tracing centres of different countries to share resources for weapons tracing.

Interpol has a total of 179 NCBs worldwide. It directly facilitates firearms tracing for its members through the Arms Section of the Public Safety and Terrorism Sub-Directorate, which issues trace requests to member countries on behalf of other members. Through Interpol's Orange Notice system, a national police authority can circulate information by fax and e-mail to all other NCBs with a request to check whether they have recovered any weapons produced or trafficked using the *modus operandi* identified with a suspect illicit manufacturer or trafficker.

Interpol also offers its members the IWETS system mentioned above. This analytical database is designed to collate information on illicit firearms trafficking worldwide and can help track stolen and recovered weapons. IWETS is currently being upgraded to allow the use of information technology that will enable NCBs to electronically request and exchange text and digital imagery to facilitate weapons tracing.

Though such systems have great promise, tracing cooperation among law enforcement agencies remains quite patchy in practice. Interpol is basically a facilitating organization; its value to members depends on their capacity to use it. Developed countries tend to use Interpol channels and resources more regularly than others. Yet, even in these countries, police authorities prefer bilateral contacts where these are established.

The infrastructure required for effective weapons tracing is not particularly expensive. For example, the cost of the US NTC—by far the largest such centre in the world—is approximately US\$15 million per year, plus an additional US\$5 million to support major projects. However, experience shows that effective tracing *does* require a significant investment of resources and attention in certain key areas, even after basic infrastructure is in place.

Tracing must be reliable and timely. Law enforcement officials typically face acute time constraints in their pursuit of specific criminal investigations. They must have reasonable confidence that weapons traces will be satisfactorily completed within the lifespan of an active investigation before they will give them much attention. For this reason, it is important to move beyond “bare bones” tracing systems to ones in which records are computerized and access to them by law enforcement officials is facilitated through simple electronic links and at least some degree of centralization.

Awareness-raising and resources are also needed to encourage law enforcement officers to conduct weapons traces systematically, so that the information needed to identify patterns and trends in sources and lines of supply is available. Developing and sharing law enforcement data going beyond the specific trace (for example, recovery location, possessor, associates, dealers) can allow links to be spotted and contribute to crime prevention and enforcement. The development of systems for web-based record-keeping and tracing, which are also interoperable with such other record-keeping systems as fingerprint and DNA databases, also appears increasingly desirable and feasible.³⁸

Where tracing systems are reasonably well-established, the most common reason for their failure appears to be inaccuracies in the identification and description of the relevant weapon. This demonstrates the need for accurate, comprehensive and easily accessible reference materials, such as Canada’s Firearms Reference Table, discussed above,

and for training and education programmes designed to ensure they are used effectively. It is also important to put procedures in place to validate tracing data at the outset. These may involve the use of computer validation software, restrictions on which personnel enter the data, or adherence to strict protocols for how data is entered.

Furthermore, effective tracing requires the development of contacts and cooperative partnerships. At the national level, relevant actors include national, provincial and local law enforcement agencies, different branches of law enforcement, and also tracing organizations, manufacturers, importers, and dealers. The cooperation of other stakeholders, including relevant NGOs and civil society groups, is often equally important to effective crime prevention and law enforcement. The development of contacts and cooperative partnerships at the regional and global levels is no less essential to successful tracing.³⁹

1.5.3 Weapons Tracing in the Context of Illicit Arms Trafficking to Conflict-Prone Regions and War Zones

Illicit trafficking of arms and ammunition to conflict-prone regions and war zones is no less illegal than that which has criminals or terrorists as intended recipients. In practice, there is often substantial overlap between these classes of activities, as is clear from the experience of countries such as Colombia. Thus, law enforcement agencies, including the police, play a legitimate and central role in combating and preventing arms trafficking to or through conflict zones, and virtually all of the discussion of tracing mechanisms in the previous section applies here as well.

Nevertheless, illicit arms trafficking to conflict zones has its own characteristics, with implications for tracing cooperation. First, transnational supply lines tend to be longer and more complex. In many cases, greater efforts are made to disguise these through the use of brokers, front companies, and “grey-market” transfers in which governments may be implicated. Second, the role of intermediaries, including brokers, dealers and transport agents, is often a critical element in such trafficking. Third, the quantity of arms (usually military-style) contained in these shipments tends to be much larger, and is usually sourced (diverted) from military and other official stockpiles, or from ex-military surplus stocks. Given these characteristics, customs services, military police and intelligence services

have a more prominent role to play in conflict weapon investigations than in the case of “ordinary” crime guns.

1.5.3.1 Military Tracing Systems

The importance of military marking, record-keeping and tracing systems derives from the importance of military source arms in conflict zone trafficking, noted above.

The armed forces of most countries maintain systems for the marking and record-keeping of arms and ammunition that are separate from those for civilian weapons. This poses some special problems. Some arms manufacturers do not uniquely mark SALW and/or ammunition produced for the military, enabling the armed forces to apply their own marks as these weapons enter into service. Large quantities of military SALW held in reserve storage may be unmarked or inadequately marked. When such weapons are subsequently diverted to the illicit market through loss, theft or corruption, they may be difficult or impossible to trace.

Similarly, for institutional and national security reasons, most countries maintain separate records for arms, parts and components and ammunition held by their armed forces. While such records are centralized and computerized in numerous countries—including Australia, Canada, South Africa and the UK—many others lack centralized national records even in paper form. In some States, different branches of the armed forces maintain separate records of their SALW inventories, with no detailed central database.⁴⁰ Further complicating the picture, many countries also maintain several security forces in addition to the military—such as border guards, interior troops, gendarmerie and special services—each with their own inventories. This kind of fragmentation of official SALW records can hamper accurate record-keeping, prevent the timely identification of losses, and obstruct or delay tracing investigations.

While all well-organized professional armed forces have systems for identifying and tracing losses of arms and ammunition from their own stocks and units, in many countries such systems are under-developed or under-utilized.

International military cooperation in tracing illicit weapons flows to conflict regions has grown in recent years. Thus, in the Balkans, NATO and

UN forces have actively sought to trace and disrupt illicit flows of arms as part of their peace missions in the region. Although much of this tracing cooperation has been ad hoc, contacts, procedures and habits have developed that have facilitated effective and timely tracing.

The institutional separation of civilian and military marking, record-keeping and tracing systems complicates tracing investigations involving illicit weapons that may have been held in military stocks. Sometimes procedures exist which enable civilian law enforcement agencies to request tracing information on recovered military weapons from the armed forces or other security services. In the US, for example, police tracing requests are forwarded by ATF to the US Army's Central Registry, with replies fed back through ATF to the requesting agency. In many countries, however, these procedures often do not function well, with the security forces' concerns with security and control of information delaying or obstructing tracing. Furthermore, in most countries, civilian law enforcement or tracing authorities are not routinely informed of military weapons losses or tracing investigations.

1.5.3.2 Tracing Illicit Arms Trafficked to Conflict Zones

In principle, the tracing of illicit arms trafficked to conflict zones raises no additional issues relating to military confidentiality or security than tracing investigations into transnational trafficking by criminal organizations. There is, in fact, considerable overlap between the two spheres. In both cases, diversion of authorized international transfers may be involved, in which case tracing investigators will need to request information from national export control authorities. Furthermore, just as many crime guns are lost or stolen from military stocks, many conflict weapons are diverted from civilian markets. A particularly important source of cross-over between the two spheres is ex-military surplus weapons that are initially transferred from official stocks to commercial dealers or authorized recipients in importing States.

National police, customs authorities and other law enforcement agencies regularly investigate suspected illicit arms trafficking networks as part of their work, just as they investigate the trafficking of drugs, cars and humans. Exactly the same systems are used for such tracing as those described in section 1.5.2 above.

That said, national intelligence services will be much more involved in tracing conflict weapons, due to the specific political and security concerns they raise. Although such services often cooperate with police and customs investigations, they tend to be less interested in collecting evidence—for a criminal prosecution, for example—than with monitoring and disrupting illicit arms flows. They are also more concerned with protecting intelligence sources and techniques than the police. This sometimes leads to accusations that they are too inclined to monitor or manipulate arms trafficking networks—as opposed to exposing and/or disrupting them.

A related problem is that many producer countries may be reluctant to provide information on their legal SALW transfers, since they may use the same brokers and arms trafficking networks that are active in the illicit trade to conflict zones.

Increasing tracing cooperation among armed forces in the context of peace missions (e.g. the Balkans) has already been mentioned. The UN has also conducted precedent-setting inquiries involving the tracing of arms flows to countries subject to UN arms embargoes. Among the most prominent is the UN International Commission of Inquiry on Arms Trafficking in Rwanda, established by the UN Security Council in 1995.⁴¹ While the exact sources used in the Inquiry were kept confidential, they included the police, Interpol, customs, intelligence services, journalists, defectors and refugees. The investigators were able to link weapons illicitly trafficked to Rwanda to commercial dealers and to countries that had inadequately enforced the embargo. The Inquiry, which had a real political impact, reached its findings on the basis of a “balance of probability”, without having to prove or further substantiate its findings.

The UN Security Council subsequently launched further inquiries into UN sanctions-breaking activities. In May 1999, it established a Panel of Experts to investigate violations of sanctions imposed on UNITA in Angola. Its report broke new ground in naming governments and individuals that it believed were implicated in sanctions breaking activities.⁴² Similar investigations have been established in relation to Sierra Leone, Liberia, the Democratic Republic of Congo, and Somalia, consolidating the precedent of international tracing inquiries under the auspices of the UN.

While the UN has gradually strengthened its capacity to conduct such inquiries—for example, through greater scope to pursue politically sensitive

investigations and through closer involvement with international organizations such as Interpol—it faces many of the same challenges and obstacles to effective tracing of illicit arms flows as national investigating authorities. In many cases, suspected source or transit countries have been unable or unwilling to cooperate with these investigations. Poor or non-existent record-keeping in supplier countries has also been a problem. The tracing of ammunition, especially for military-style SALW, is even more difficult, for reasons already cited in the paper.

Much of the information that has been uncovered on the trafficking of illicit arms to conflict zones has come through extensive investigations of brokers and transport agents. Efforts to improve the tracing of conflict weapons will thus need to focus on the paper trail left by these actors.

1.5.4 Emerging Norms and Good Practices in International Weapons Tracing

Although international cooperation between law enforcement agencies in tracing crime weapons has a long history, the recent adoption of the UN Firearms Protocol is an important landmark. The prospects for substantially enhancing international cooperation in weapons tracing depends significantly on progress in implementing this Protocol.

Although the UN Firearms Protocol establishes legally-binding international standards for marking and record-keeping, its commitments on cooperation in tracing lack specificity. The main obligation is that:

States Parties shall cooperate in the tracing of firearms, their parts and components and ammunition that may have been illicitly manufactured or trafficked. Such cooperation shall include the provision of prompt responses to requests for assistance in tracing such firearms, their parts and components and ammunition, within available means (Article 12, paragraph 4).

To facilitate such cooperation, in this and all other areas covered by the Protocol, “each State Party shall identify a national body or a single point of contact to act as liaison between it and other State Parties on matters relating to this protocol” (Article 13, paragraph 2). Article 14 also provides, in a general way, for the provision to States parties, on request, of the

training and technical assistance necessary to enhance their ability to implement the Protocol.

As noted in section 1.2, the UN Programme of Action also includes a number of politically-binding commitments to promote cooperation in SALW tracing. Participating States undertake to “strengthen the ability of States to cooperate in identifying and tracing in a timely and reliable manner illicit small arms and light weapons” (II, paragraph 36), and to “cooperate with each other, ... and, where appropriate, with relevant international, regional and intergovernmental organizations, in tracing illicit small arms and light weapons, in particular by strengthening mechanisms based on the exchange of relevant information” (III, paragraph 11). They also commit “to establish or designate, as appropriate, a national point of contact to act as liaison between States on matters relating to the implementation of the Programme of Action” (II.5), and to establish or designate a similar point of contact within sub-regional and regional organizations for the same purpose (II.24).

These are useful norms and standards, but will require elaboration and systematic follow-up if practical gains are to result.⁴³ Only the obligations to identify national and regional contact points are sufficiently specific to provide a clear focus for efforts to promote subsequent implementation. In a well-functioning national tracing system, it is increasingly normal to expect a response to a tracing request within hours, or at least within a few days. But there is, as yet, no guidance on this and other key issues in the above instruments—such as which authorities can legitimately expect cooperation with a tracing request and what information can reasonably be expected.⁴⁴

Some regional initiatives contain more significant commitments with respect to tracing than their global counterparts.⁴⁵ The OAS Convention contains virtually the same obligations to cooperate in tracing (Article XIII. 3) and to identify a national body or single point of contact (Article XIV. 2) as those found in the UN Firearms Protocol. However, it also provides for cooperation through exchange of experience and training in the “identification and tracing of firearms, ammunition, explosives, and other related materials” (Article XV.2.a), and establishes a Consultative Committee to promote and facilitate exchange of information and experience with marking and tracing, among other matters (Article XX).

In the OSCE Document on SALW:

The participating States agree to cooperate with each other on the basis of customary diplomatic procedures or relevant agreements and with intergovernmental organizations such as Interpol, in tracing illegal small arms. Such cooperation will include making available, upon request, relevant information to the investigating authorities of other participating States. They will also encourage and facilitate regional, sub-regional and national training programmes and joint training exercises for law enforcement, customs and other appropriate officials in the small arms field' (III.E.4).

Participating States also:

agree to share, in conformity with their national laws, and on a confidential basis through appropriate and established channels (for example Interpol, police forces and customs agencies) information on seizures of illicitly trafficked small arms, including the quantity and type or weapons seized, their markings and details of their subsequent disposal (III.E.6 (ii)).

In addition, the OSCE document includes a number of information exchange and transparency arrangements that, although not directly relevant, should contribute to a climate that encourages cooperation in tracing.

The SADC Protocol also commits States parties "to establish appropriate mechanisms for cooperation among law enforcement agencies ... to promote effective implementation of this Protocol", including systems for rapid information exchange, promotion of cooperation with international organizations such as Interpol and the World Customs Organization, and the use of existing data-bases (Article 15). It also establishes helpful information exchange systems and mutual assistance arrangements (e.g. Articles 14 and 16).

These regional agreements reinforce the recently established global standards and norms described above, while providing a framework for improving capacity in weapons tracing at the regional level. Thus, in the Americas, the SALSA initiative described in section 1.4 will be linked to a parallel system called FASTRACS, which will give law enforcement agencies in the region confidential access to the network for purposes of tracking the movement of specific weapons.

This highlights one of the most important areas of emerging good practice—developing regional and sub-regional tracing cooperation, and enhancing access by law enforcement agencies in developing countries to the expertise and resources of neighbouring industrialized States, including at the local level. For example, firearms tracing resources in Florida, as well as those of the US NTC, could be made more readily available to support tracing activities in neighbouring Caribbean countries.⁴⁶

Significantly, several of the international agreements for enhanced tracing cooperation apply not only to illicit weapons, but also to illicit ammunition, explosives and other related materials. In fact, national authorities have a clear interest in being able to trace all of the illicit materials that they encounter. However, the relative lack of international norms for the marking and record-keeping of ammunition and explosives is bound, in practice, to obstruct the tracing of such items.

1.6 ISSUES FOR THE SCOPE AND IMPLICATIONS OF AN INTERNATIONAL TRACING MECHANISM FOR SALW

1.6.1 Introduction

As previously discussed, substantial global norms have recently been agreed for tracing illicit SALW and in the related areas of marking and record-keeping. However, past experience with efforts to enhance international cooperation has shown that clear agreement on international norms, though necessary, is not sufficient to ensure appropriate follow-up and implementation. This is particularly true where implementation raises sensitive issues, rules and procedures remain unclear, and significant development of existing practices and institutions is required.

Cooperation in tracing illicit SALW is no exception. As discussed, substantial improvements in marking, record-keeping and tracing systems are needed. Moreover, experience in tracing conflict weapons is still quite limited. Such traces may sometimes raise sensitive political and security issues, both domestically and internationally. The national, regional and international institutions that must be involved in such tracing cooperation will probably require clearer guidelines, rules and procedures before they embark on it routinely.

In this final section, we consider the implications of an international arrangement or mechanism for tracing illicit SALW, including the question of its possible scope and content. This discussion builds on the findings of the four technical studies and the previous sections of this paper.⁴⁷

1.6.2 Scope and Purposes of an International Mechanism for Tracing Illicit SALW

An international mechanism for tracing illicit SALW would be part of the follow-up to the 2001 UN Small Arms Conference. As such, one of its main purposes would be to promote the implementation of relevant Programme of Action commitments, especially to strengthen and facilitate inter-State cooperation in identifying and tracing illicit SALW in a timely and reliable manner. It would be global in scope and aim to complement, reinforce and promote consistency with relevant provisions in regional agreements, including the OAS Convention, the OSCE Document and the SADC Protocol. It should also make use, where appropriate, of existing national, regional and international organizations and institutions, including relevant UN bodies, Interpol and the World Customs Organization.

The relationship between a new international tracing mechanism for SALW and the Firearms Protocol requires careful exploration. As discussed in section 1.2, in practice there is substantial overlap in the scope of the Protocol and the UN Programme of Action. The definition of a “firearm” in the Firearms Protocol is broad and covers many types of SALW. While the Protocol is primarily concerned with the prevention, investigation and prosecution of illicit SALW manufacturing and trafficking—specifically where these offences are transnational in nature and involve an organized criminal group—its scope is probably wide enough so as to make it relevant to most of the problems that the UN Programme aims to address.

This implies that a new international tracing mechanism for SALW must in practice contribute to the implementation of both the UN Programme of Action and the UN Firearms Protocol. It would be a “self-standing” mechanism within the broad framework of the UN Programme, and also a mechanism that facilitates tracing cooperation in the context of the Firearms Protocol. Crucially, it could also help to ensure that the commitments and processes relating to marking, record-keeping and tracing in the UN Programme and the Firearms Protocol remain in close alignment.

An international tracing mechanism for SALW could contribute to the overall purposes outlined above in several ways. It could aim to:

- clarify and develop international standards, procedures and mechanisms to ensure and strengthen international cooperation in tracing illicit SALW;
- clarify, develop and strengthen international standards for SALW marking and record-keeping;
- establish or facilitate processes for identifying and promoting best practices and lessons learned in respect of SALW marking, record-keeping and tracing;
- establish or support mechanisms, institutions and programmes to promote the implementation of commitments and best practices relating to marking, record-keeping and tracing, including international cooperation and assistance.

Since each of these aims is important, it may be wise to design an international tracing mechanism that could potentially contribute to all of them. In the first instance, commitments agreed within the mechanism would apply within the framework of the UN Programme of Action. However, in order to maintain overall coherence, any new standards could also be adopted as part of the UN Firearms Protocol.

In considering the priorities for an international tracing mechanism, it is important, however, to focus on the near future. The international standards for *marking and record-keeping* contained in the UN Firearms Protocol and the UN Programme of Action emerged after difficult negotiations. Their limitations and weaknesses do not derive from a lack of attention or knowledge, but rather reflect the limits of international consensus at this stage. Thus, it may not be realistic or desirable to immediately re-open these debates.

A better, initial approach might instead involve clarifying standards and procedures for cooperation in *tracing* illicit SALW—an issue which was largely neglected due to a lack of time during negotiations. Alongside this, international programmes to promote cooperation and assistance in implementing existing standards for marking and record-keeping, and to identify and disseminate best practices, would probably be widely acceptable. These would not only be useful in their own right, but could

also lay the basis for future negotiations aimed at strengthening such standards.

An important question concerning the international tracing mechanism is whether to establish it through a legally-binding or politically-binding instrument. There are several advantages to the legally-binding option. This would strengthen its normative force, stimulate the transposition of relevant regulations into domestic law, and provide a clear legal basis for any new institutions, incentives or sanctions that might be established to promote implementation. Yet, there are also disadvantages. Legally-binding agreements usually take longer to negotiate and enter into force, with governments typically delaying implementation until this has happened. Legally-binding treaties can also be harder to revise in the light of experience. Finally, governments tend to be more conservative in formulating legal commitments. Experience shows that politically-binding agreements can be at least as effective as legal instruments, provided they are precisely formulated and the political will for implementation is strong.

The earliest date that international negotiations could realistically begin on a legally-binding instrument for tracing illicit SALW is probably early 2004—provided the UN Group of Governmental Experts concludes that such an instrument is feasible and desirable and the UN General Assembly recommends negotiations occur at its autumn 2003 session. In the meantime, there may be scope for launching a voluntary political agreement to facilitate tracing cooperation among a coalition of willing governments. If well-crafted, such a voluntary arrangement could help accelerate the implementation of commitments to cooperate in tracing, and also furnish practical experience on which future negotiators could build.

1.6.3 Possible Elements of an International Tracing Mechanism for Illicit SALW

1.6.3.1 Cooperation in Tracing

The top priority for any international tracing mechanism would be to reaffirm and strengthen the central international norms on tracing cooperation noted at the beginning of section 1.6.1 above (and described in sections 1.2.3 and 1.5.4), and to clarify how these should be implemented through the elaboration of more specific international standards, procedures and mechanisms.

Some of the necessary elements are already agreed as part of the UN Firearms Protocol or the UN Programme of Action. These include the establishment or designation of points of contact for purposes of facilitating cooperation on tracing, and the exchange of information on national marking systems.

These standards could be elaborated and strengthened. At present, the exchange of information on national marking systems is voluntary (UN Programme of Action, section III, paragraph 12). Yet, it is essential that relevant authorities be able to recognize the key elements of other countries' marking systems and thus rapidly identify at least the country of manufacture or of legal importation, and reliably communicate the full set of marks required for unique identification of the relevant weapon. It may also be important to specify what is required of national contact points in tracing enquiries—for example, that they should be able to respond to requests relating to every type of weapon and situation covered by the mechanism, including weapons of military origin and arms seized in the context of conflict zone trafficking and UN sanctions breaking.

The tracing mechanism could also usefully clarify what might reasonably be expected in the way of “timely and accurate” responses to requests for tracing information. Many national tracing systems now normally expect to receive responses within hours, and at least within 2-3 days. International minimum standards are needed in order to align expectations and prevent undue delays. States should undertake to develop and maintain national tracing systems capable of responding within agreed timeframes, subject to reasonable exceptions.

Furthermore, the tracing mechanism could specify the minimum information States requesting and responding to a trace should supply. Requesting States could be expected to provide such information as identifying marks, other information which could assist with the identification of the weapon (such as a photograph or description), and confirmation that it is, or is believed to be, illicit. Minimum information which would be expected of responding States could include: confirmation that the weapon was manufactured in or imported by the State; information on the manufacturer or importers; the date of manufacture or importation; details of the legal transfer of the weapon out of the State (including dates, transfer points, transit States and the authorized final recipient); and reference codes of the transfer or customs documentation to facilitate

further tracing. Where there was no record of the weapon being legally transferred out of the country, the State could be expected to promptly confirm this fact, and provide results of the ensuing investigation.

Since the tracing mechanism would apply to all forms of illicit SALW trafficking, including that relating to conflict zones and sanctions breaking activities, the minimum information indicated above should be made available irrespective of the nature or status of the weapon or of specific transfers. States involved in the legal transfer of the weapon at some point are not necessarily responsible for its subsequent diversion into illicit markets. Yet, the cooperation of all States is needed if diversion points and illicit trafficking routes are to be identified and disrupted.

Another key issue concerns the kinds of actors that could legitimately use the tracing mechanism. These would undoubtedly include the State that has recovered or seized the illicit SALW under investigation, States conducting investigations on behalf of this State (where it lacks the resources needed to carry out the trace), and States from whose territory the weapons were diverted. Such actors would probably also include the UN—including UN investigative bodies established to investigate sanctions breaking activities—and relevant regional organizations and perhaps also NGOs. While, as a matter of principle, participating States could be encouraged to cooperate with tracing requests made by each of these actors, it will be important to specify which of them can expect full cooperation and in what circumstances.

A further issue relates to the uses that could be made of information provided to assist with tracing. Key here is the question of confidentiality. Existing international cooperation in weapons traces among police or customs authorities is conducted under a norm of confidentiality, with provision for presenting the information in court and thus making it public. Similar principles should probably be applied to the international tracing mechanism. However, additional issues and sensitivities—such as the use of information relating to State-to-State transfers or losses from military stocks—will also need to be addressed.

In this regard, it is to be hoped that the international tracing mechanism will not limit itself to facilitating criminal investigations geared towards prosecution, but will also enable appropriate authorities to identify, monitor and disrupt arms trafficking activity. This implies that intelligence

on sources and lines of supply of illicit SALW should be regularly shared among governments and international bodies involved in preventing and reducing such trafficking.

The international tracing mechanism might usefully include measures to develop or strengthen systems for exchanging, collating and analyzing information relating to illicit SALW traces. Interpol mechanisms and resources, such as IWETS, are especially relevant in this context. States could be encouraged or required to provide information gathered from tracing investigations for inclusion in Interpol databases. However, it is possible that Interpol mechanisms for information sharing may need to be reinforced or supplemented for this purpose.

Interpol is normally used by police in criminal investigations, but the tracing mechanism will likely extend to areas not normally dealt with by Interpol, such as loss or diversion from military stocks, or conflict weapons trafficking. In principle, Interpol mechanisms can be used for investigations into any type of illicit arms trafficking, including trafficking to conflict zones.⁴⁸ Nevertheless, this will at least have to be brought to the attention of Interpol members. Additional protocols may also be needed on the use of IWETS and other Interpol resources by the UN and Interpol member States for purposes of tracing illicit arms shipments to conflict zones or States subject to UN arms embargoes. It might also be useful to develop supplementary procedures and mechanisms to strengthen cooperation of this kind—for example between authorities tracing weapons lost from military stocks.

1.6.3.2 Promoting Good Practices and Developing International Standards on Marking and Record-Keeping

An international tracing mechanism could establish programmes or mechanisms to identify and promote best practices in marking and record-keeping. These, in turn, would help strengthen tracing capabilities and facilitate agreements to develop and strengthen international standards.

From the outset, opportunities should be pursued to ensure that all participating authorities are aware of existing resources and expertise—such as the RCMP's Firearms Reference Table—so that these are more widely shared and used. Systems to facilitate cooperation and resource

sharing at sub-regional, regional and international levels should be encouraged and supported.

Possibilities for strengthening international standards in marking and record-keeping could be explored during preparations for the establishment of the international tracing mechanism. For example, it may be possible to agree on extending the minimum periods during which records should be maintained, or to develop broad norms for marking ammunition, parts and components, and explosives. Clearer undertakings on the marking of unmarked or inadequately marked weapons in official stockpiles may also be within easy reach. If agreements on such matters could be readily achieved, they could form part of the future international tracing mechanism. Otherwise, they could be considered at meetings of the parties following the establishment of the mechanism, with guidelines for good practice or new standards included as technical annexes to the mechanism.

Beyond this, an international consultative or advisory body could be established to provide technical advice to assist efforts to improve national marking, record-keeping and tracing systems.⁴⁹ Such a body might consist of technical experts from around the world, prepared to advise on techniques and emerging best practices relating to such key issues as: the marking of parts and components, ammunition and explosives; the placing and organization of marks; techniques for covert secondary marking and other processes to safeguard against efforts to sanitize marks; the design and implementation of computerized record-keeping systems, including Web-based systems; and systems for the reliable identification and communication of marks for tracing purposes.

1.6.3.3 Promoting International Assistance

The UN Programme of Action and the UN Firearms Protocol both include undertakings to encourage international assistance to promote effective implementation of these instruments. However, the mechanisms and programmes for providing such assistance remain unspecified. There are many possible sources of technical and financial assistance, and there are advantages to retaining flexibility. Nevertheless, it may be useful to establish some specific international measures or programmes to facilitate assistance.

In promoting international assistance, two key challenges are to match needs with available resources, and to ensure appropriate coordination and information-sharing. Experience shows that this does not happen automatically. One possibility would be to establish clearing-house mechanisms, so that potential recipients can more easily identify available resources and vice versa. Another option is to establish international resource centres, where relevant authorities can go to obtain specialist advice or resources relating to marking, record-keeping and tracing. In practice, an effective international tracing mechanism would probably be associated with a number of international, regional and national resource centres, such as those in southern Africa, the Americas, and Europe, discussed in sections 1.4 and 1.5 above.

1.6.4 The Implications of an International Tracing Mechanism for Illicit SALW

The technical studies for the UNIDIR/SAS Study Group, together with this overview paper, have sought to describe and clarify existing practices and standards relating to marking, record-keeping and tracing, and to explore the possible scope and contents of an international mechanism (or mechanisms) for tracing illicit SALW. It is clear that there are many challenges to ensuring effective systems for marking, record-keeping and tracing, and also important opportunities to develop and strengthen them.

In general, the main obstacles are not technological. Advanced and effective techniques for marking and record-keeping are available and there is experience in using them. The challenge for all States is to ensure that decisions are taken and resources allocated so as to ensure effective and consistent marking, record-keeping and tracing at the national, regional and international levels. As we have seen, important international and regional norms and standards have been agreed in recent years—in the UN Programme of Action and the UN Firearms Protocol, and in such regional agreements as those of the OAS, OSCE and SADC. An international mechanism for tracing illicit SALW would build on these—specifically in the context of the UN Programme follow-up—to enable and facilitate international tracing cooperation.

An international tracing mechanism would be no panacea. The small arms problem is exceedingly complex and requires measures going far beyond weapons tracing. Yet, tracing is a key component of these efforts.

International efforts to develop and strengthen the tracing of illicit small arms can build capacity to conduct criminal investigations and successfully prosecute cases. They can also help States and international organizations to identify and monitor sources and supply routes for illicit small arms, and to take action to prevent or disrupt such supply—including supply to conflict zones and States under arms embargo. This latter aspect is especially important for a tracing mechanism situated within the framework of the UN Programme of Action.

There are many issues that need to be addressed in designing and developing an effective international mechanism for tracing illicit SALW. The improvement of systems for marking, record-keeping and tracing is a continuous task. Nevertheless, there are important opportunities for moving rapidly towards the establishment of an international tracing mechanism. It is hoped that this study will serve as a useful resource to the international community as it seeks to take advantage of these opportunities in the coming months and years.

Notes

- ¹ The members of the SAS/UNIDIR Study Group were: Peter Batchelor; Ilhan Berkol; Christophe Carle; Owen Greene; Michael Hallowes; Keith Krause; Patricia Lewis; Glenn McDonald; Frédéric Schütz; Gary Thomas; and Michel Wéry. All members of the Group participated in their personal capacities; their views did not necessarily coincide with those of their organizations. In addition, Nadia Fischer, Olivier Guerot, René Haug, Ambassador Rakesh Sood and Stefano Toscano contributed valuably to the discussions at a meeting of the Study Group in April 2002.
- ² The technical papers prepared for the SAS/UNIDIR Study Group were: Michael Hallowes, *Marking and Record-Keeping Systems and Modalities of Operation*; Gary L. Thomas, *Structures and Institutions Necessary to Support the Effective Operation of a Firearms Tracing Mechanism*; Frédéric Schütz, *What to mark and what to trace? The Implications of Selecting Categories and Types of SALW for Inclusion in a Tracing Mechanism*; Michel Wéry and Ilhan Berkol, *Traceability of Light Arms: a comparison of the main existing international mechanisms*.

- 3 *Programme of Action to Prevent, Combat and Eradicate the Illicit Trade in SALW in All its Aspects*, Report of the United Nations Conference on the Illicit Trade in Small Arms and Light Weapons in All Its Aspects, United Nations Document A/CONF.192/15, July 2001, as endorsed by the UN General Assembly at its 56th Session.
- 4 *Report of the Panel of Governmental Experts on Small Arms*, United Nations Document A/52/298, United Nations, New York, 7 August 1997. See also the *Report of the Group of Governmental Experts on Small Arms*, United Nations Document A/54/258, United Nations, New York, 3 August 1999.
- 5 These issues are explored in detail in F. Schütz, op. cit. note 2.
- 6 United Nations Programme of Action to Prevent, Combat and Eradicate the Illicit Trade in Small Arms and Light Weapons in All Its Aspects: Section II, paragraphs 7, 8, 9, 10, 16, 21, 36, 37; Section III, paragraphs 6, 9, 10, 11, 12, 14; and Section IV, paragraph 1c.
- 7 Organization for Security and Co-operation in Europe, *OSCE Document on Small Arms and Light Weapons*, FSC.DOC/1/00, Vienna, adopted 24 November 2000; Southern Africa Development Co-operation, *Protocol on the Control of Firearms, Ammunition and Other related Materials*, adopted at Blantyre, 14 August 2001.
- 8 France and Switzerland, *Food for Thought Paper*, United Nations Document A/CONF.192/PC/7, 28 February 2000; France and Switzerland, *Establishing a Tracing Mechanism to Prevent and Reduce Excessive and Destabilising Accumulation and Transfer of Small Arms and Light Weapons*, Working Paper, United Nations Document A/CONF.192/PC/25, 10 January 2001; France and Switzerland, *Chairs' Summary*, Franco-Swiss Workshop on Traceability of Small Arms and Light Weapons: Tracing, Marking and Record-Keeping, Geneva, 12-13 March 2001, reproduced in United Nations Document A/CONF.192/PC/38, Annex of 23 March 2001.
- 9 Organization of American States, *Inter-American Convention against the Illicit Manufacturing of and trafficking in Firearms, Ammunition, Explosives, and other Related Materials*, adopted at Washington DC, 14 November 1997.
- 10 Inter-American Drug Abuse Control Commission's (CICAD's), *Model Regulations for the Control of the International Movement of Firearms, their Parts and Components, and Ammunition*, 2 June 1998.
- 11 *Protocol Against the Illicit Manufacturing of and Trafficking in Firearms, their Parts and Components and Ammunition*, supplementing the

United Nations Convention against Transnational Organized Crime, United Nations Document A/RES/55/255, 8 June 2001.

- ¹² As discussed in M. Wéry and I. Berkol, op. cit. note 2.
- ¹³ More detailed information can be found in the associated papers from this study, particularly the papers by M. Hallows, op. cit. note 2 and F. Schütz, op. cit. note 2. See also: Canada, *Marking Small Arms: An Examination of Methodologies*, Department of Foreign Affairs and International Trade, Ottawa, Canada, February 1999; Ilhan Berkol, *Marking and Tracing Small Arms and Light Weapons: Improving Transparency and Control*, GRIP Report, Groupe de Recherche et d'Information sur la Paix et la Sécurité (GRIP), Brussels, 2002.
- ¹⁴ About 20% of illegal handguns recovered in the UK have been the subject of sanitization efforts. M. Hallows, op. cit. note 2.
- ¹⁵ For example by NATO and UN forces in relation to arms flows to armed groups in the former Yugoslavia. See *ibid.*
- ¹⁶ CIP member States: Austria, Belgium, Czech Republic, Chile, Finland, France, Germany, Hungary, Italy, Spain, Russian Federation, Slovakia and the United Kingdom.
- ¹⁷ See, for example M. Hallows, op. cit. note 2.
- ¹⁸ To cite two examples, the UK uses this system, while South Africa will adopt it from January 2003. Thus, a British SA80 rifle is marked with a unique identifier such as UE 85 A000001 (U = code for country of manufacture (UK); E = British Factory Code (Enfield); 85 = year of manufacture (1985); A000001 = serial number.
- ¹⁹ Thus, the symbol is used to distinguish between identical weapons, marked with the same alphanumeric code, manufactured at different factories.
- ²⁰ F., Schütz, op. cit. note 2.
- ²¹ See M. Wéry and I. Berkol, op. cit. note 2.
- ²² M. Hallows, op. cit. note 2.
- ²³ M. Wéry and I. Berkol, op. cit. note 2; see also I. Berkol, op. cit. note 13; and O. Greene, *Enhancing Traceability of Small Arms and Light Weapons Flows: developing an international marking and tracing regime*, Biting the Bullet Project Briefing No. 5, Basic/International Alert/Saferworld, London, 2000.
- ²⁴ These issues are discussed further, for example, in M. Wéry and I. Berkol, op. cit. note 2, and F. Schütz, op. cit. note 2. See also *Report of the Group of Experts on the Problem of Ammunition and Explosives*, United Nations Document A/54/155, 5 June 1999.

- 25 This section draws on discussions within the SAS/UNIDIR Study Group and on each of the four technical papers prepared for the SAS/UNIDIR Study Group.
- 26 The UK is quite typical in this respect. Although it now maintains a well-developed centralized national database on weapons held in armed forces' inventories, it does not yet have a national database covering all firearms in private or commercial ownership. M. Hallowes, *op. cit.* note 2.
- 27 G. Thomas, *op. cit.* note 2.
- 28 For an alternative view, see I. Berkol, *op. cit.* note 13.
- 29 M. Hallowes, *op. cit.* note 2.
- 30 Organization of American States, General Assembly Resolution AG/RES.1797 [XXXI-0/01], 5 June 2001.
- 31 <http://salsa.oceanus.ca/>
- 32 European Community, Directive 91/4777EEC, 1991.
- 33 *South Africa Police Service Firearms Tracing Pilot Project*, quoted in M. Hallowes, *op. cit.* note 2.
- 34 G. Thomas, *op. cit.* note 2.
- 35 *Ibid.*
- 36 ATF has created three regional Crime Gun Centres in Chicago, New York City and Washington DC, with a fourth due to open in 2003 in Los Angeles.
- 37 M. Hallowes, *op. cit.* note 2.
- 38 G. Thomas, *op. cit.* note 2.
- 39 M. Hallowes, *op. cit.* note 2, and *ibid.*
- 40 An example is the US, where each branch of the armed services maintains its own, computerized records. Small Arms Survey, *Small Arms Survey 2002*, Oxford University Press, Oxford, 2002, p. 261.
- 41 The UN International Commission of Inquiry on Arms Trafficking in Rwanda, established pursuant to United Nations Security Council Resolution 1013, 7 September 1995, and reactivated in 1998 by United Nations Security Council Resolution 1161, 7 May 1998.
- 42 *Report of the Panel of Experts on Violations of Security Council Sanctions against UNITA*, in Annex 1 of United Nations Document S/2000/203, 10 March 2000.
- 43 As discussed, for example, by O. Greene, *op. cit.* note 22.
- 44 Lack of clarity about such issues provided part of the motivation for the French-Swiss initiative.
- 45 See also M. Wéry and I. Berkol, *op. cit.* note 2.

- ⁴⁶ This issue was raised during the SAS/UNIDIR Study Group Workshop discussion, Geneva, April 2001.
- ⁴⁷ See also France and Switzerland, *op. cit.* note 8 and O. Greene, *op. cit.* note 22. See M. Wéry and I. Berkol, *op. cit.* note 2, for a discussion that differs in some respects from this authors' analysis on this issue.
- ⁴⁸ As discussed in M. Hallowes, *op. cit.* note 2.
- ⁴⁹ This was proposed in the context of the French-Swiss Initiative, France and Switzerland, *op. cit.* note 8.

BIBLIOGRAPHY

- Berkol, Ilhan, *Marking and Tracing Small Arms and Light Weapons: Improving Transparency and Control*, Rapport du GRIP, Groupe de Recherche et d'Information sur la Paix et la Sécurité (GRIP), Brussels, 2002.
- Canada, *Marking Small Arms: An Examination of Methodologies*, Department of Foreign Affairs and International Trade, Ottawa, Canada, February 1999.
- France and Switzerland, *Establishing a Tracing Mechanism to Prevent and Reduce Excessive and Destabilising Accumulation and Transfer of Small Arms and Light Weapons*, Working Paper, UN Document A/CONF.192/PC/25, 10 January 2001.
- France and Switzerland, *Food for Thought Paper*, reproduced in UN Document A/CONF.192/PC/7, 28 February 2000.
- France and Switzerland, 2001, *Chairs' Summary*, Franco-Swiss Workshop on Traceability of Small Arms and Light Weapons: Tracing, Marking and Record-Keeping, Geneva, 12-13 March 2001, reproduced in United Nations Document A/CONF.192/PC/38, Annex of 23 March 2001.
- Inter-American Drug Abuse Control Commission (CICAD), *Model Regulations for the Control of the International Movement of Firearms, their Parts and Components, and Ammunition*, adopted at Washington DC, 2 June 1998.
- Owen Greene, *Enhancing Traceability of Small Arms and Light Weapons Flows: Developing an International Marking and Tracing Regime*, Biting the Bullet Project Briefing No 5, Basic/International Alert/Saferworld, London, 2000.
- Programme of Action to Prevent, Combat and Eradicate the Illicit Trade in SALW in all its Aspects, *Report of the United Nations Conference on the Illicit Trade in Small Arms and Light Weapons in All Its Aspects*, United Nations Document A/CONF.192/15, July 2001.
- Protocol against the illicit manufacturing of and trafficking in firearms, their parts and components and ammunition, supplementing the United

Nations Convention against Transnational Organized Crime, United Nations Document A/RES/55/255, 8 June 2001.

Organization of American States, *Inter-American Convention against the Illicit Manufacturing of and trafficking in Firearms, Ammunition, Explosives, and other Related Materials*, adopted at Washington DC, 14 November 1997.

OSCE, *Document on Small Arms and Light Weapons*, FSC.DOC/1/00, Vienna, adopted 24 November 2000.

Report of the Group of Experts on the Problem of Ammunition and Explosives, United Nations Document A/54/155, 5 June 1999.

Report of the Group of Governmental Experts on Small Arms, United Nations Document A/54/258, 3 August 1999.

Report of the Panel of Governmental Experts on Small Arms, United Nations Document A/52/298, 7 August 1997.

Small Arms Survey, *Small Arms Survey 2002*, Oxford University Press, Oxford, 2002.

Southern Africa Development Co-operation, *Protocol on the Control of Firearms, Ammunition and Other related Materials*, adopted at Blantyre, Malawi, 14 August 2001.

World Forum on the Future of Sport Shooting Activities (WFSF), *Firearms Marking: Model Standards and Common Serial Number Codes*, Report of WFSF Workshop, Olbia, Italy, 22-24 June 2000.

CHAPTER 2

WHAT TO MARK AND WHAT TO TRACE? THE IMPLICATIONS OF SELECTING CATEGORIES AND TYPES OF SALW FOR INCLUSION IN A TRACING MECHANISM

Frédéric Schütz

2.1 WHAT ARE THE VARIOUS CATEGORIES OF SALW?

The problem of how to define small arms and light weapons (SALW) has long existed and is international in scope. It is a problem that deserves particular attention and which, in spite of the innumerable discussions held on the topic, has remained unsolved. In order to resolve it, the focus must supersede semantics and examine the various elements comprising this terminology so that its meaning and scope may be better understood.¹ To speak of SALW is all very well, but is this actually the appropriate term? What exactly does it refer to?

Grasping the problem posed by the different categories of SALW implies first formally presenting the concept of firearms from different viewpoints.

From a technical point of view, a firearm is an instrument of attack or defence that is activated when a projectile is expelled by the force of gases expanding during the rapid combustion of an explosive mixture.² Antipersonnel mines, for example, do not correspond to this definition, and yet they are considered SALW. The above definition is also interesting because it brings to the fore the political, legislative and conflict-related aspects which, as we will see throughout this paper, are in constant contradiction with one another and yet are closely linked, as Figure 1 illustrates.

Figure 1: The relationship between political, legislative and conflict-related problems

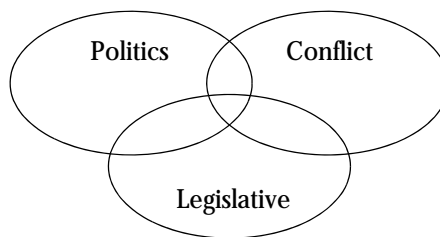

Le Petit Larousse illustré³ defines a weapon as “*an object, device or instrument which, by its nature or its use, serves to attack or to defend oneself.*” The interest of this definition lies in its illustration of the general way in which weapons are perceived. Here, semi-automatic pistols, assault rifles and machine guns all fall into the category of firearms. It does not, however, reveal which difference or differences exist between a firearm and SALW.

The categories currently proposed by the UN for inclusion under the heading of SALW are based mainly on politically-motivated arguments, since the UN defines SALW as weapons that can be carried by an individual, draft animal or light vehicle. This of course applies to many weapons whose real maximum calibre is 100 mm, including handguns (revolvers, semi-automatic pistols), shoulder-fired weapons (shotguns and assault rifles) and mortars, to name but a few. It is therefore a very broad classification that spans the largest weapon categories, and it reveals a need for sub-divisions that would better allow the weapons in question to be identified—particularly for the purposes of database use. We will go into detail regarding the difficulties raised by this type of definition in section 2.2.

Everyone knows what a pistol or a revolver is, and what each represents. Structurally speaking, this classification poses no problem. However, there is such a huge difference between the Swiss-issue revolver of 1882 and the F2000 of today (both of which fit the description of an SALW given above) that it would be impossible to envisage using the same mechanism for tracing these two types of weapon—particularly with respect to searching in registers. Given that it is impossible to choose a single

tracing method for all SALW (contrary to what certain political figures would have us believe), breaking them down into categories thus becomes a necessity—and an interesting undertaking.

On a purely technical level, firearms are classified according to the criteria that distinguish the type of weapon in question—whether it is a revolver, a handgun, or other type of weapon; its calibre, usually expressed either in millimetres or an Anglo-Saxon measure, i.e. hundredths or thousandths of an inch; the number of its barrels and type of bore (smooth or rifled); the rate of fire and the type of ammunition it uses. The advantage of definitions based on technical features is that a weapon in a given category can be classified according to its characteristics, without necessarily having to resort to a more or less exhaustive list that would constantly have to be kept up-to-date.

In parallel, the World Forum on the Future of Sport Shooting Activities (WFSA) highlighted in a report issued in 2001 certain problems that exist in relation to the current classification of SALW, and proposed that small and light weapons be defined as “lethal weapons of war which are capable of full automatic fire”.⁴

Naturally, the definitions of SALW (or in broader terms, firearms) vary greatly from one country to another, which obviously makes it harder to decide on a single type of classification. Unifying SALW implies harmonizing the legislation of the different countries. In Switzerland, the law (*Recueil Systématique*—RS 514.54) defines arms in Article 4, paragraph 1, as:

- a. devices that allow projectiles to be launched by means of a propelling explosion, or objects which can be transformed into such devices (shoulder-fired or hand-held weapons);
- b. devices designed to cause sustainable damage to human health by the vaporisation or spraying of a substance;
- c. daggers or knives with switch blades, collapsible or retractable blades, flick-knives, spring-operated knives or daggers, or others whose opening mechanism can be operated with a single hand;
- d. devices designed to harm human beings, notably knuckle-dusters, simple or spring-operated truncheons, throwing stars, throwing knives and powerful slingshots;

- e. devices that produce electrical shocks that may impede the ability of human beings to resist or sustainably harm their health.

The definitions of the weapons outlined above are mainly a function of the effects they produce rather than of their technical characteristics. Swiss legislation makes particular mention of knives, which are not considered under the UN classification. Knives and daggers are weapons in the full sense of the word (they can be the objects of illicit trafficking or may be used to commit crimes) and they must not be left out of our study.

Although these considerations raise many questions, they do allow us to distinguish the following categories of weapon: light weapons and heavy arms (including howitzers and tanks). Light weapons are divided into two broad categories—hand-held weapons and shoulder-fired weapons. This latter category is technically defined by the number of barrels and type of bore—i.e. rifled or smooth—as shown in Appendix 1. This classification, which is more precise than that of the UN and is based on technical elements, should be applied to each of the broad categories of arms. This type of categorization has the added advantage of providing a clearer picture of the weapons involved in armed conflict and in criminal activities. We will insist on the importance of this point throughout this paper.

In order to gain a better understanding of the impact of SALW on crime (including armed conflict), additional parameters need to be taken into consideration (they will be set forth and discussed throughout this paper). This approach highlights the existence of two major means of distinguishing weapons: technical features, and so-called “criminal” characteristics.

SALW can also be classified according to status. The method used to trace a weapon differs depending on whether it is illicit, illegal, unauthorized, military, civilian or its use has been restricted. This is why it is indispensable for SALW to be distinguished using their technical and criminal characteristics (including their status). For the purpose of developing a more appropriate tracing mechanism, it is therefore essential to consider all these parameters in order to correctly categorize a weapon and better target it in a trace. No such comprehensive mechanism has yet been developed.

The division of weapons into three categories as described above is shown in Figure 2.

Figure 2: : The different sub-categories of SALW

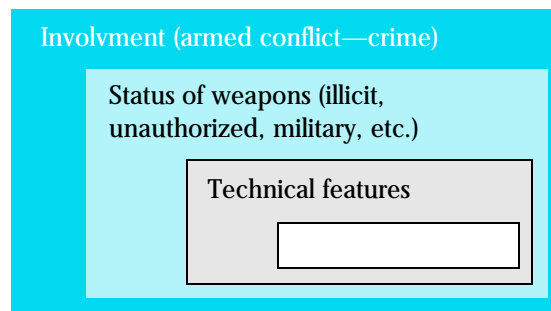

It is interesting to see here how the categorization and definition of weapons differ according to the purpose and the environment in which they are used. A definition of “arms” that is too broad causes a significant bias in the analysis of statistics concerning the impact these weapons have on crime.

2.2 WHAT ARE THE CONTROVERSIAL ASPECTS OF THE CATEGORIZATION OF SALW?

Whether the context is an armed conflict or a criminal organization, firearms are omnipresent and cannot be considered as ordinary commodities. The only way to effectively trace them is if all weapons were subject to marking, registration and tracing in perfectly well established and coordinated operations at the regional, national and international levels. Such measures unfortunately cannot be applied today to the categorization of SALW or to their widespread use.

The widespread distribution of SALW and their illicit involvement in armed conflicts has reinforced the political will to purely and simply ban firearms. People who maintain that “SALW cause serious physical and psychological damage to children” or “in times of conflict, SALW carry violence to a climax...” are not speaking of the weapons that effectively play a role in violence. Which weapons are these, and what is their real impact? Who has never heard of a Kalashnikov? Kalashnikovs are included in the categorization of SALW, but what of their history and technical

characteristics? What are the differences between an AK-47 and an AK-74?⁵ These are the real questions that expose the anonymity propagated by the current method of categorizing SALW. In order to be able to trace a weapon effectively, it must first be recognizable and describable—particularly in the context of making use of the various existing registers and databases. The prevailing anonymity hinders this process.

In this context, it is interesting to note that although antipersonnel mines are considered SALW, SALW do not distinguish between blast mines, directional or standard fragmentation mines, or bounding fragmentation mines. Although these are all types of antipersonnel mine, they produce different effects and are built differently. Similarly, the category of small weapons includes shotguns, semi-automatic rifles and “ordinary” handguns. But to what degree can these weapons be considered on an equal basis given that the effects they produce are drastically different? That these objects are very different from one another must be kept in mind—lumping them together in the same category is a mistake.

There is also incompatibility between the “political” categorization of SALW, the application of technical solutions for marking them, and the use of the criminal data pertaining to these weapons. The current definition of SALW includes guns, revolvers and even mortars, and yet not all these weapons are used in armed conflict or to commit crimes or offences. Too broad a definition is thus an obstacle to identifying the weapons involved in a case, because all the weapons are treated in the same way irrespective of the damage they cause or the danger they represent. It is nonetheless patent that a tank differs from a semi-automatic gun—both physically and with respect to the effects it produces. The fact of categorizing SALW is correct, but extending this categorization in political discourse to cover too many objects makes it incompatible with the tracing measures that governments are attempting to establish.

Experts must therefore take care not to confuse weapon categories: so-called weapons of war can indeed be used in shooting sports, just as hunting and sporting weapons may be used to commit crimes or to supply illegal markets. The problem then becomes how to regulate such a system. Things are made even more confusing by the fact that all these weapons are grouped together under the general heading of SALW. Under which circumstances should a weapon be traced, then? Which weapons should be included in the tracing process?

In order to better grasp the problem of categorization, another interesting tack is to establish a link between the different types of crime and the weapons used. We note that handguns are mainly used for misdemeanours (i.e. criminal acts whose network structures are loose or involve only one individual), while certain larger-calibre weapons are reserved for small but better organized criminal groups (organized gangs, etc.). It is thus necessary to identify the weapons in question in order to be able to effectively target the perpetrators. These remarks lend support to the idea that there should be a distinction made between armed conflict and crime. Generalizing SALW means treating the different types of crime that exist in the same way. The experts are nevertheless unanimous on this point: to treat crimes in such an undifferentiated manner is to disregard reality.

The difficulty of categorizing firearms in the different databases and registers is also a major obstacle to the establishment of accurate statistics. Having categorizations that are too broad or that vary considerably among the countries or IT systems involved in a given case can mean that investigations are inappropriate or that tracing operations are (needlessly) bogged down. For instance, how can a type of firearm be linked to a type of crime committed if the categorization simply refers to “small and light weapons”? Specialized fields have a more specific categorization that respects the diversity of the different types of firearm, being based as it is mainly on the technical aspects of the weapons. Experts therefore find themselves in a situation where the definitions of SALW used by the UN, law enforcement agencies and firearms professionals are not compatible with one another.

A final, important point is that the current categorization of SALW and their definition does not correspond to the legal definitions in the different States (as shown by the example of South-East Asia).⁶ This observation underscores the necessity to harmonize legislation so that everyone speaks the same language. Political and legislative will currently do not support such a standardization.

2.3 WHAT FEATURES OF THE VARIOUS CATEGORIES AND TYPES ARE SIGNIFICANT FOR A TRACING MECHANISM?

First of all, it should be recalled that the process of tracing can take several different forms. According to ISO standard 8402, tracing is defined as “the aptitude to uncover the history, usage or location of an entity by means of registered identifying features”. This definition highlights the importance of the notions of identification and registration in the context of a trace, as depicted in Figure 3.

Figure 3: The different stages of the tracing process

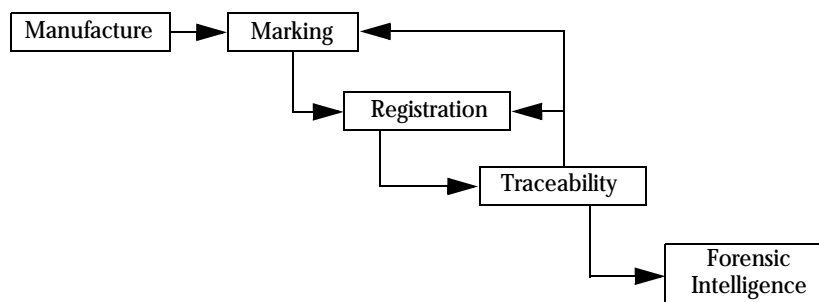

Intelligence or forensic intelligence can be defined as “a method that consists of the methodical search for and disclosure of links among elements of criminal data on one hand, and on the other between criminal data and other possible significant data, for the purposes of legal and police applications”.⁷ Analyzing the data then allows links to be established between different cases, if similarities are identified, by supplying pertinent information about the identification of a weapon and its association with a criminal network, for example. But which elements should be included to allow a firearm to be effectively traced and identified? We will examine the different options available to us in the context of a PT (perfect tracing) and a PGT (pretty good tracing).

It is therefore inadequate to tout the benefits of tracing all SALW; tracing is not a solution in and of itself. Specific measures must be established for each category of weapon, especially when we consider that

SALW include weapons of war, defence weapons, as well as hunting and sporting weapons. Should different measures not be applied to each type of weapon that experts have to deal with? Let us now attempt to identify the characteristics of the different categories and types of SALW that would optimize tracing operations.

With this goal in mind, two broad divisions become readily distinguishable: *intrinsic* elements (i.e. those elements that relate to the weapon, such as the serial number and technical features) and *extrinsic* elements (those features that instead relate to the crime with which the weapon is associated and to the information contained in the police reports). Let us take a closer look at these two classes.

On a purely technical basis, marking—and especially the serial number—enables only the identification of the last legitimate owner. Thus, marking alone is not sufficient to effectively trace a weapon as it only allows a part of its history to be reconstituted (in fact, its primary purpose is to allow a weapon or object in general to be identified). Marking also discloses the name of the weapon's manufacturer and, in certain cases, the date of manufacture (as with the semi-automatic Colt *1911*), as well as technical information about the weapon (its calibre, etc.) and information linked to any stamps on the weapon.

Taken together, these elements are useful to identify a weapon, and obtaining them constitutes the first level of a tracing operation. In this case, how would it be possible to trace a weapon—i.e. monitor its involvement in different transactions—in illegal circles? The answer to this question leads us to the second level of the intelligence exercise. The identification of the perpetrators, the detection of criminal networks, and the monitoring of weapon flows are made possible by the use of extrinsic data. For this reason, all the registered data concerning the weapon must allow it to be linked to both a technical and a criminal history. It may seem completely unrealistic to hope to obtain such information for weapons involved in armed conflicts, but we will look at the extent to which experts nevertheless manage to pinpoint certain trends.

We shall now attempt to integrate the notions of forensic intelligence into the subject at hand. It is indeed interesting to note that one of the recurring practices of arms traffickers is the means they use to obliterate firearm serial numbers,⁸ which would suggest that it is essential to take into

account elements of the investigation such as the *modus operandi* or the location in which the weapon was recovered, seized or stolen. These elements can then be included in the intelligence operation and provide a dynamic picture of the flow of weapons, the detection of criminal networks and the identification of perpetrators. Police reports contain a large amount of information that is useful (and necessary) for tracing operations. However, considering the vast amount of data collected and the federal pluralism that is typical of Switzerland (and of many other countries), the information contained in the different files varies greatly. The solution, then, lies in finding a means of correctly using these different sources of information. Currently, the tracing mechanisms that have been implemented in the different countries do not have recourse to these extrinsic elements, which is one of the reasons that tracing operations today are limited to a small number of weapons. In order to extend the range of weapons that can be traced (in the context of a PT), these elements should be rapidly integrated into the tracing process. Figure 4 shows an example of a database input screen that includes all these features. The fields provided are not exhaustive and may be amended or modified.

Figure 4: Example of a screen containing information on the intrinsic and extrinsic features of a weapon

Technical Features of the Weapon		Investigator
Type	<input type="text"/>	<input type="text"/>
Make	<input type="text"/>	Date <input type="text"/>
Model	<input type="text"/>	Location <input type="text"/>
Calibre	<input type="text"/>	Type of offence <input type="text"/>
Serial number	<input type="text"/>	Method of obliteration <input type="text"/>
No. of barrels	<input type="text"/>	
Bore :	<input type="checkbox"/> smooth <input type="checkbox"/> rifled <input type="checkbox"/> combined	
Statut :	<input type="checkbox"/> civilian <input type="checkbox"/> military <input type="checkbox"/> stolen <input type="checkbox"/> illicit <input type="checkbox"/> other	
Modus operandi :	<input type="text"/>	

The following questions should therefore be taken into consideration with respect to extrinsic elements: what types of firearm are used to commit homicides and aggravated robberies (or any other type of offence)? What types of firearm do the police recover? Were the weapons stolen or did they enter the country illegally? Where do they come from?⁹ Considering the effort required to set up such a system, any solution for a PGT would thus take into account existing data (currently very much under-utilized) in the different law enforcement agencies and other institutions. Analyzing this data would bring fresh, relevant elements to the investigation.

On the basis of the above, tracing can thus be defined as the capacity to uncover the history of a weapon and to link cases to one another if similarities are observed, whether in connection with the technical characteristics or with the elements of the criminal investigation. We have also emphasized the importance of the presence of the serial number in the partial reconstitution of the history of a weapon, and the significant contribution of information from forensic intelligence. This is why it is important to (1) precisely define the types of firearm involved, (2) to review the current categorization and definition of weapons, and (3) to include extrinsic elements in the global tracing process.

It is furthermore important to recall that, in spite of all these shortcomings, the tracing operations currently being carried out by law enforcement officers and other institutions (BATF, Viva Rio, etc.) are producing significant results.

2.4 WHAT ABOUT AMMUNITION?

The involvement of ammunition and the elements related to ammunition in tracing operations remains a grey area; there has been no in-depth examination as to the appropriate measures to apply with respect to marking and tracing operations. What is more, there is no mention in Swiss law of any standards to be adopted with respect to marking and tracing measures, whether for firearms or for ammunition. This is an area in dire need of rapid clarification.

It is important to recall that ammunition is as dangerous as a firearm, and that it is an integral part of the various illegal networks and trafficking operations. The amount of cartridges produced on a daily basis by the

different manufacturers is staggering, and is in fact one of the major problems—especially given that they are not necessarily “consumed” in the context of military, sporting or hunting activities, and that certain people may also stockpile them. The fact that ammunition has no identifying marker to speak of signifies that it is impossible to identify any of it (which effectively means that obliterating any marks visible on the cap of the case serves no purpose). This is why it is necessary to develop measures that permit the identification of initially 1) the ammunition, and 2) the route it has followed and the transactions in which it has been involved from its date of manufacture. Today, the lack of standards for marking and tracing ammunition makes checking this information impossible. When one considers that 389,877 cartridges were found in three separate warehouses in Africa,¹⁰ how can we even imagine being able to trace their journey? For the moment, the only thing experts can do is to concentrate on the marks on case caps and on registers of sale. Even then, results are not guaranteed.

We should not neglect to mention that there is ammunition bereft of any marking whatsoever; it is used in science laboratories to study the different traces left by a weapon. The absence of any mark on these cartridges means that they cannot be traced either, and experts find themselves facing a wall.

Let us examine the different options available in order to try and remedy this situation. Technically speaking, five elements constitute a cartridge: the projectile, the case, the powder, the primer cup and the primer. If we are to trace the ammunition, we must be able to use these five elements to mark it.

Initially, it is essential to determine and formalize the information that should appear on a cartridge. Studying the marks on a cartridge should supply us with a series of information about the manufacturer, the date and place of manufacture, the calibre and the composition of the primer. It may be relevant for a criminal police investigation to obtain precise information as to when the ammunition was manufactured, which constitutes the first step towards a trace in the strict sense of the word. Although the dates inscribed on case caps can provide a general indication, this type of information will nevertheless have to be obtained from the manufacturer.¹¹

All of this data, while useful from a technical point of view, is too vague to offer sufficient details for a proper trace. It nevertheless represents a good alternative in the context of a PGT.

To further illustrate our point, the batch number that may appear only on the boxes containing cartridges is of no use once the ammunition has been removed from its original packaging. Since ammunition is a dangerous good,¹² it is in theory possible for it to be monitored during transportation by means of a coding system common to the different States and located on the box of ammunition.

In order to address these different shortcomings in arms marking, the technical solutions being considered for the firearms themselves can also be applied to ammunition. The solutions proposed are reasonably applicable in the context of a PGT; applying all the solutions proposed hereafter would be tantamount to conducting a PT.

Let us first look at the options available for marking the powder and the primer. A solution could be envisaged for marking and tracing explosives (RS 941.411—*Ordonnance sur les substances explosibles* (Regulation on explosive substances), articles 18, 19, 20 and 23). The various markers used for this purpose (HF-6[®], Microtaggants[®] and Explotracer[®]) could constitute an excellent basis for marking the powder and primer of firearms ammunition. Tests must be conducted to determine whether this marking of ammunition is feasible; a similar approach would then have to be applied to all the other types of ammunition that fall into the SALW category, such as that used in missiles.

In parallel, marking the body and/or the cap of the case with a laser engraving would allow for all the information pertinent to the tracing of the ammunition to be codified (the contents of this information would still have to be formalized). This marking could take the form of a bar code, matrix coding or simply an alphanumeric code. The reactions that occur during the firing process (dilation of the casing, residue or grease deposits, marks made by the weapon, and so on) must not alter the marking and thus risk hindering the capacity to trace the ammunition.

Marking the base of the projectile (for fully jacketed projectiles—TMJ) could also be a viable alternative. In this case, marking would have to take place during the manufacturing process, prior to the final assembly of the

different cartridge components. Today, several such prototypes have been developed, descriptions of which are available in several publications (see Appendix 3).¹³

Once the technique has been selected, the next step is to decide on the information to be contained in the marking. As in the case of firearms, an identifier that individualizes each cartridge is indispensable. This is why ammunition also must bear an individual, unique “serial number” (in the context of a PT); information about the manufacturer, the place and the date of manufacture can also be included. The fact that a casing presents a smaller surface than a firearm nevertheless is important: the amount of information that can be contained on a casing may therefore be insufficient depending on the marking method that has been chosen. The content of the marking will also have a great influence on the choice of codification.

It should be recalled that applying all of these markings would result in a perfect tracing or PT solution. However, it is inconceivable to have cartridges—each one comprising a different number—laden down with inscriptions intended only to be used for tracing. Moreover, considering the number of different political bodies involved, such a feat seems quite impossible. Therefore, marking that aims to accomplish a reasonably good tracing process for a PGT would consist of applying one of the techniques proposed. To this end, each of these markings must be evaluated from the point of view of factors such as readability, durability, and even possibilities of codification before a decision is taken. Considering the morphology of the different cartridges that exist and the feasibility of these techniques, marking by laser would seem to be the best alternative. Moreover, a batch number appears to be sufficient in this case.

To conclude, we would like to point out that the process of reloading allows users of firearms to recuperate the empty case and fill it with another dose of powder, a new projectile and a new priming cap to obtain a “new” cartridge ready for use. It is therefore possible that the marking present on a cartridge (either on the frame and/or the cap of the case) may no longer correspond to the ammunition in question if the latter has been reloaded.

2.5 WHAT ARE THE CRITERIA FOR INCLUDING OR EXCLUDING ANY OF THE MAIN TYPES OF SALW?

To identify these criteria, we must first recall the different categorizations and difficulties that were set forth in the context of sections 2.1 and 2.2. The first element to be taken into account has to do with the legal definitions of weapons in the different States, which vary greatly and are not about to be harmonized. Faced with such differences, how can we then hope to identify a feature that will allow a type of weapon to be included or excluded?

We have stressed the importance of the various weapons' technical characteristics in establishing a proper categorization. We have also examined the use of elements relating to forensic intelligence for the purpose of determining whether a weapon belongs to a criminal network or whether it has already been used to commit a crime, or simply with a view to facilitating tracing operations. However, can all weapons be placed under the SALW “label”?

Classifying a type of weapon in one of the SALW categories according to the various definitions set forth in this paper can be problematic in certain cases, as the following example shows. At the beginning of January 2002, the cargo vessel *Karine-A* was stopped in the Red Sea. The ship was carrying 83 containers filled with 50 tons of weapons of Iranian origin: mortar shells, Sagger missiles, RPGs, explosives, mines, ammunition and Kalashnikov assault rifles.¹⁴ What category of SALW does an RPG belong to? In what way can the tracing process be applied, considering the great variety of weapons and ammunition found on board the vessel? Currently, tracing missiles (not to mention other types of weapons) is not a priority for law enforcement officers; indeed, the mechanism for doing so appears to be even more vague than that used for “simple” handguns. This is why efforts must be centred on the weapons that are most commonly found in criminal circles and illicit trafficking circuits. But which weapons are these? At the same time, it would be of interest to develop a tracing mechanism suitable for all SALW. In the context of a PGT, the latter however, is not a reasonable solution; instead, the mechanisms that already exist must be formalized and optimized.

According to the UN definition, tracing SALW entails tracing handguns, as well as missile launchers, mortars and anti-aircraft guns. By consulting the various statistics and studies that have been compiled, it is possible to establish a list of the weapons most commonly used in criminal acts. Or, as we mentioned earlier and as Greco has also observed,¹⁵ it is at least possible to establish a link between the types of weapons used to commit crimes and offences (whether or not they are expensive, or powerful) and the degree of organization of the criminal network involved (i.e. simple, as in the case of a single individual, or more complex). Therefore, tracing operations must primarily target those types of weapons that are primarily involved in criminal activities.

Technical criteria can also help us to better identify the weapons to be included in the SALW category. Here, the definition given by Gallusser *et al* in the context of section 2.1 allows us to dispense with certain types of weapons. Antipersonnel mines, tanks and mortars would thus be excluded from the SALW category in this context.

Depending on the definition of weapons being used and the type of crime being considered, the classification of the weapons changes. The weapons involved differ according to the type of crime the experts decide to cover. It is obvious that trafficking in tanks or missile launchers is different from trafficking in handguns; that there is a difference in the criminals involved in these cases is also obvious. One of the determining criteria is thus the link between a weapon and the type of crime for which that weapon might be used (this is the first category as shown in Figure 1).

To close this chapter, an interesting question can be put forward: is it SALW that define the tracing process, or is it the process that defines the weapons that are involved and which must therefore be traced? The answer to this question will provide pertinent information with respect to the weapons that are lumped together under the very broad heading of SALW.

2.6 WHICH SALW SHOULD BE THE SUBJECT OF A TRACING MECHANISM? WHY?

We have already referred to the problem of unwittingly lumping all kinds of weapons under the label of SALW. SALW undoubtedly must be

traced, but which ones? Precisely which weapons are we talking about in this context? Let us take a look at the problem we face when trying to answer these questions.

We have stressed the dichotomous aspect of the weapons involved in armed conflict and in crime. This distinction must form the basis of our attempt to address the above questions—we must examine both dimensions and adapt the tracing mechanism to each of them. Many have so far been in favour of tracing all weapons, but such a policy would encounter insurmountable obstacles. The decision to trace certain weapons has been made on the basis of political considerations rather than objective and technical criteria. Therefore, initially we must concentrate on the weapons that must as a priority be subjected to tracing operations, and in parallel develop methods that allow weapons that may present a problem to be traced as well.

Another question surfaces when studying the issue of which weapons must be traced: should the research carried out concern the source (i.e. the number of weapons held, imported or exported in a given country), or rather the activity (that is, relate to the crimes committed)? This point is fundamental because the source and the activity refer to two completely different groups of weapons. Considering that not all SALW can be traced and that the idea is to provide statistical information for tracing operations, this author feels that the primary area of interest should be weapons involved in criminal activities.

Today, in the vast majority of cases, antique weapons are not included in traces (we shall go into greater detail on this point in section 2.8). Considering the problems raised by this type of situation, the idea of identifying (meaning counting and recording) all the weapons in circulation around the world or that each person possesses becomes interesting. The example of Canada shows that since the new arms law (under which all firearm owners must declare their weapons and have them registered, whereas the old law applied only to firearms with restricted authorization) came into effect on December 1, 1998, the number of requests for tracing has increased and the situation concerning firearms, their possession and their use has clearly become more transparent. Nevertheless, this type of approach has its problems: tracing all the weapons implies implementing special cells dedicated to these operations. As the number of cases to be dealt with has steadily increased, a rapid response (a function of police

efficiency) can only take place if such cells are operational. Given the necessity for the greatest possible speed, the best solution is to opt for a PGT in which the marking techniques used do not require an unwieldy infrastructure to decode and transmit the information. Because of the fact that it is a long-term and large-scale process, it is impossible to reasonably develop this type of cell on such a large scale.

Let us consider for a moment the fundamental objectives of a firearm tracing mechanism. We must not lose sight of the fact that the goal of such a process is not to wipe out crime or armed conflicts, but rather to help to identify the criminal networks and their members through which the weapon has circulated. This leads us to a level of analysis that is much more interesting than the mere fact of resorting to the serial number to determine the last legitimate owner of the weapon. Because of the fact that, in numerous cases, this serial number can be erased by a criminal act or simply by the more or less “aggressive” character of the weapon's environment, we need to focus on another approach to tracing weapons and determining their links with criminal elements or a series of crimes.

The amount of weapons currently on the market numbers about 550 million units. Some of these weapons are involved in armed conflict as well as in everyday criminal activities. For this reason, tracing operations must not be restricted only to weapons involved in armed conflicts as some organizations maintain; these operations must also assist the police to effectively fight arms trafficking and the criminal activities linked to these weapons.

To lay the groundwork, let us take a look at the different statistics and studies available so that we can determine which are the main weapons involved in armed conflicts and criminal activities.

In Canada and the US, various studies and statistical reports have shown that weapons that are the object of tracing operations are not only weapons involved in armed conflict or those involved in crime. In some cases, tracing requests come about as a result of simple routine checks linked to illegal firearms possession. Furthermore, the statistics show that a wide variety of weapons are the objects of tracing operations (see Table 1). It is also important to recall that the weapons concerned by the two broad fields of armed conflict and criminal activity are not always the same. This difference is essential when it comes to choosing which weapons to trace.

Table 1: Firearms recovered in crime-related and non-crime-related incidents in 1995¹⁶

Firearm categories	Crime-related		Non-crime-related		Unknow nature	
	Number	%	Number	%	Number	%
Rifles/shotguns	247	52.2	189	56.6	7	29.2
Handguns	97	20.5	61	18.3	5	20.8
Restricted rifles	0	0	1	0.3	0	0
Prohibited firearms with shortened barrels	19	4	13	3.9	0	0
Other prohibited firearms	4	0.8	0	0	0	0
Replicas/imitation weapons	7	1.5	0	0	0	0
Air rifles	94	19.9	66	19.8	11	45.8
Other/unspecified	5	1.1	4	1.2	1	4.2
Total	473	100	334	100	24	100

Various studies carried out in Canada concerning firearms recovered or seized by the police in 1995 and 1997 have produced the following results (see Tables 2 and 3).

Table 2: Types of firearms recovered or seized by police in 1997¹⁷

Type of weapons	Number
Carbines and rifles	236
Handguns	58
Other restricted-authorization firearms	2
Firearms with sawed-off barrels	29
Other prohibited weapons	13
Air weapons	61
Replicas/limitation weapons	18
Starting pistols	12
Other/unidentified	13
Total	442

Table 3: Categories of firearms recovered in 1995¹⁸

Type of weapons	Number
Carbines/shotguns	443
Handguns	163
Restricted-authorization carbines	1
Prohibited firearms with shortened barrels	32
Other prohibited weapons	4
Replicas/imitation weapons	7
Air rifles	171
Other/unspecified	10
Total	831

These studies have shown that carbines and rifles represent the weapons most commonly used to commit criminal offences. 72% of the weapons used in homicide cases were handguns. Of the 67 homicide cases, 52% of the weapons came from illegal sources. Let us not forget that certain weapons intended for civilian use can be used in armed conflict.¹⁹

Paradoxically, although antique weapons too should be traced, as we will see later on, it is either difficult or impossible to do so.

Unfortunately, studies like those above remain few in number for the moment. It would be interesting to carry out similar studies in all of the world's large cities and then to compile a comparative database on weapons recovered by police in the context of serious and petty crimes. Such a study is currently being carried out in Switzerland, but what of the other countries? It would also be interesting to be able to compile statistics on the weapons used in armed conflict. However, such a feat seems a more difficult and even idealistic undertaking, given the erratic counting methods that would be used. Nevertheless, an article published in the Swiss daily newspaper *24 heures* (4-5 May 2002 edition, p. 2) reported that "the harvest from operation Rampart exceeded all expectations: 1,949 Kalashnikovs, 2,563 precision rifles, 779 guns, 81 telescopic rifles, 93 machine guns, 23 explosives laboratories, 430 explosives charges, 8

explosives belts and dozens of tons of explosives”. In this case, there was a majority of long weapons, which indicates that it would be a good idea to focus in particular on this type of firearm for tracing operations in the context of armed conflict.

What the example of Brazil shows us is that there is a certain link between crime and armed conflict. Because the life of a firearm can span several decades, it is not uncommon for a weapon to be involved in several criminal cases, in armed conflicts, or simply to be moving from one country to another and used in both types of activities. Each year during the 1990s, the Brazilian police seized more than 7,000 firearms, which included handguns (revolvers and guns) and long weapons (AR-15, AK-47, SIG Sauer, etc.). Which of these weapons should be targeted for tracing? It matters little whether or not they are SALW: what is important is to be able to trace the history and the route followed by each of these weapons in order to determine their source and the principal individuals involved. Each State has the answer in its relevant statistics (crimes and offences committed, illicit trafficking, etc.).

Additional studies are therefore indispensable to ensure the optimal tracing of all SALW; for the time being, it is difficult to establish a precise list of the weapons that should be traced. Each State ought to develop the capacities that would provide a clearer picture of the current situation regarding firearms and crime.

2.7 DO ANY CATEGORIES OR TYPES OF SALW REQUIRE SPECIAL TYPES OF MARKING? IF SO, WHICH ONES AND WHY?

The composite parts of a weapon vary from one type to another. For this reason, it is impossible to make a global decision for all the weapons as to which parts to mark; each type of weapon must be considered individually. Certain categories of weapon may therefore require specific marking.

It is also important to note that the marking technique may vary depending on the material comprising the support to be marked—whether it is metal, polymer and so on. Today, weapons are increasingly

sophisticated and are comprised of increasingly diverse materials (polymers, alloys, etc.). Semi-automatic Glock® pistols are characterised by their polymer frames (the remainder of the weapon is metal). There is a similar trend currently for certain types of assault rifle.

Marking may also vary according to the size of the weapon and that of its constitutive elements. Here again, the SALW classification proposed by the UN does not allow for an appropriate solution to be taken. If we follow its assumption that the standard should be to mark all SALW on the firing pin, how can this standard be applied to a tank? Generalising in the case of SALW is therefore not the right answer. Certain weapons require a particular—or even a personalized—type of marking.

Coherent and efficient marking is therefore a matter of having detailed knowledge of the components of a firearm. Appendix 2 contains an illustration of the different marking options that exist. The same approach can and should be adopted with respect to all the categories of weapons included under SALW. Manufacturers are also an invaluable source. Each manufacturer can propose locations for marking each type of weapon. In this context, a technical expert committee could even be appointed to evaluate each of the proposals for marking the weapons and their components.

The major difficulties encountered by the BATF (Bureau of Alcohol, Tobacco and Firearms) during arms tracing are shown in Table 4.

Table 4: Main problems encountered when tracing a firearm²⁰

Problems encountered during firearms tracing	Percentage
Problem with the weapon's serial number	13
Registration record of the weapon not available	7
Problem with the name of the importer	7
Problem with the name of the manufacturer	4
Registers not available	1
Expiry of the 20-year deadline for conserving the registers	1

This data provides an interesting account of the difficulties encountered, the shortcomings of the tracing mechanism and the solutions that can be implemented to remedy them. For the moment, many weapons require new markings, since the majority of the problems encountered in Table 4 were related to the weapon's serial number.

Davey²¹ has pointed out that weapons from the manufacturer Glock[®] have a particular marking system that shows when components have been changed during the weapon's lifetime. A letter (*G* in the case of the frame, *S* for the slide and *L* for the barrel) is added as a prefix to the serial number to indicate that this part has been changed. This type of marking therefore allows someone to discover part of the weapon's history simply by reading the existing serial number.

The technique of dual marking is also an interesting solution for firearms. It is based on one readily visible marking in combination with another—a so-called “invisible” one. This marking can be applied using different, more or less sophisticated techniques. Thus, if one of the weapon's marks is obliterated, the weapon can still be traced due to the remaining mark. Were it adopted, this dual marking system would have to be highly formalized. We are nevertheless forced to admit that this technique goes far beyond the requirements of a PGT; it is however perfectly in line with those of a perfect tracing operation. This is why when considering the options for a reasonable solution for marking, dual marking cannot be the chosen method.

Weapons intended for armed and police forces should also have special marks. Given that these weapons can also be stolen (or used for all types of crime), they should be rapidly distinguishable from civilian weapons in the context of a trace. The incident in Lausanne, Switzerland, is a perfect example of this (see Appendix 4). Swiss weapons have a distinguishing feature in their marking whereby the prefix *A* for “Army” appears on the serial number of military weapons, facilitating their identification. Knowledge of the different markings used is therefore essential to the ability to trace a firearm effectively. In the context of a reasonable tracing solution, the use of current marking practices and familiarity with their codification provides useful indications on the weapon in question. The logical approach would therefore be to work on these markings first and foremost, and to establish a register of their different forms. Marking all weapons currently on the market—desirable though it

is—remains unrealistic, which is why a reasonable solution would be to first tackle the weapons that are registered, whose trace is easy to locate. The Canadian experience in this respect can serve as an example.

Given the above observations and depending on the type of weapon being considered, the following essential components should be marked.

Handgun	Revolver	Long weapon
Frame Barrel Cylinder	Frame Barrel Firing pin Ejector Extractor Magazine	Frame Barrel Firing pin Ejector Extractor Magazine

The targeted objects and the marking technique should be discussed further. Let us remember that the serial number must appear several times on the weapon, in places that are not readily visible or are difficult to access. If this is the case, only one part of the serial number (for example, the last three digits) need be repeated, in the interest of having a shorter mark.

We reiterate the importance of taking into consideration each category of weapon individually in the setting of standards regarding the positioning of the marks. For now, a tracing mechanism that is suited to the current marking methods must be adopted, even though logically it is marking that should be adapted to the tracing operations.

2.8 ARE THERE ANY SALW THAT CANNOT BE INCLUDED IN ANY TYPE OF TRACING MECHANISM?

From a technical point of view, every weapon should be traceable by means of its serial number or other distinguishing identifier. Unfortunately, law enforcement officers face several obstacles in this endeavor: (1) antique weapons (those that did not receive any particular registration marking when they were made, or whose marking is insufficient), (2) weapons currently in circulation but whose marking is not standard, or (3) those

weapons belonging to illicit circuits. The exchange of information and collaboration among States is thus made more difficult when it comes to tracing these weapons. It is equally noteworthy that searching through the different files—which are sketchy, disparate, or even in certain cases non-existent—makes tracing operations cumbersome.

The marking methods proposed must thus be applicable to the weapons currently on the market. So far, the majority of these weapons pose a problem for police forces, given that they are involved in all sorts of trafficking activities and illicit circles (drugs, money laundering, etc.). The absence of marking and monitoring of certain weapons encourages them to be used fraudulently, and makes them even more difficult to identify.

To avoid this type of situation, a standard imposing the marking of firearm components during the manufacturing process must be included in marking standards.

The problem of antique weapons is a topical one. Data from the BATF shows some interesting trends. The percentage of failures among the BATF's tracing operations demonstrates that, in spite of the technological advances of the past few years, certain weapons are still either difficult or impossible to trace since they have not been included in any registers. The BATF furthermore has compiled a list of weapons that can no longer be traced, dubbed: *too old to trace*.²² This label comprises weapons dating back to the beginning of the last century, for which it is impossible to consult a register. Note that the BATF does not trace weapons that date from before 1990 because of the lack of registers necessary for tracing operations.²³ This is why the technical (intrinsic) elements and the intelligence/investigative (extrinsic) elements are necessary to a tracing operation and should be integrated into these files. To conclude on the problem of old weapons, the Small Arms Survey has also highlighted that all the innovations relating to the tracing process “tended to be more effective with the registration of new weapons and to ignore the stockpile of old weapons with no licence or registration”.²⁴ Registration, like marking, is an indispensable element in tracing operations. In this context, the Canadian example shows that the majority of handguns involved in criminal affairs had not been registered (see Table 5).

Table 5: Handgun registration according to case type²⁵

	Cases of a general nature %	Cases of weapons found %	Type of case unknow %
Registered handguns	30.3	47.9	35.5
Unregistered handguns	69.7	52.1	64.5

It is clear, then, that statistics can do much to help identify the weapons that are being traced. The BATF example highlights interesting examples in this respect. A study carried out by Kopel²⁶ has revealed that assault weapons were the most commonly traced because of their morphology, which is evocative of war and war crimes, as against traditional revolvers such as the Smith & Wesson, which are commonly found in any worthy collection.

It is important to emphasize that the statistics of the BATF are not representative of weapon-related crime for several reasons. First, no weapons manufactured before 1990 are traced because of the absence of existing registers for these weapons. Moreover, the weapons that are traced are in fact traced not in the context of criminal investigations linked to serious crimes or offences, but rather in the context of simple checks for legal or illegal arms possession, for the most part.

Let us recall that arms and ammunition manufacturers are free to make whatever marks they wish on their products as there are no standard rules governing this area. The experts therefore find themselves faced with (1) weapons that may have no marks, (2) weapons with duplicated numbers, or simply (3) weapons that are not registered. It is interesting to note that in Switzerland, there is no national database to speak of which records all the weapons available on the market; this is an impediment to the data exchange necessary for the tracing process to work well. In this respect, the Swiss daily newspaper *24 heures* (23-24 February 2002, p. 17) estimates that more than 420,000 Swiss citizens have a military weapon (such as the 1990 assault rifle) in their homes, but giving a precise figure is a difficult task as there is no relevant centralized register. In this case, how can one

imagine being able to effectively trace a weapon given such shortcomings and the absence of solid data? The knowledge of weapons-related criminal and technical data is a *sine qua non* condition, in the context of a PT, that allows experts to optimize tracing operations and to propose a clearer and more up-to-date picture of the situation with regard to crime and armed conflict.

Such shortcomings can be explained by the fact that certain countries (like China) are loath to deliver information about the weapons in circulation within their borders—for strictly military reasons.

Let us also not forget that in Switzerland there are many collectors or simply amateurs of arms who have numerous undeclared weapons. Before the federal law on firearms (or LArm) came into force, some Swiss cantons kept registers of collectors and other owners of weapons requiring a permit (essentially weapons considered as implements of war). Since the law came into effect, only foreigners who hold an “A” or a “B” residence permit are monitored by the cantonal authorities [Gallusser, private conversation, 2000]. Collectors’ firearms are likely to escape being monitored.

Weapons that do not require a purchasing permit can also hamper the tracing mechanism. How can such weapons be kept track of when they have not been registered, given that it is entirely feasible that they may be used with the intention to commit crimes or simply to kill?

Home-made and illegally manufactured weapons also pose serious problems for the tracing mechanisms that are currently in place. In this respect, the Small Arms Survey pointed out that there were “in South Africa, between 20,000 and 30,000 home-made weapons in circulation in 1997; between 1994 and 1999, 16,781 home-made arms (including rifles, guns and revolvers) had been recovered. This figure represents 16% of the total number of illegal arms recovered by the police”.²⁷ These numbers show how widespread the problem is; resorting to technical features alone—including the serial number—would not allow this type of weapon to be traced effectively.

In conclusion, the Viva Rio study on the weapons recovered by the Brazilian police allows us to better appreciate the merits of a tracing mechanism. In spite of the shortcomings we have highlighted throughout this paper, tracing operations can produce useful results; in the context of

a PGT, more efficient use should nevertheless be made of the technical and criminal information related to a weapon.

2.9 WHAT ARE THE IMPLICATIONS OF THE VARIOUS OPTIONS?

In section 2.10, we will examine the various marking options applicable to the weapons domain. The use of innovative marking systems inevitably leads to the development of new reading/detection methods, which means that the same innovative technologies are likely to generate additional costs that may hamper their development and implementation. Which methods can be applied to antique weapons? How can weapons that are not declared be registered? How can the firearms already in circulation be marked? These are the questions that remain difficult to answer for the moment.

With good reason, we have mentioned the use of investigative elements to increase the chances of success of tracing operations. In the same vein, Greco²⁸ has emphasized that police reports should contain information relating to the characteristics of the weapon recovered or seized, the type of activities linked to the weapon (drug trafficking, criminal act, etc.), the types of weapons found and their similarities, the computerized criminal records of the individuals involved, the method used to obliterate the serial number, if applicable, where the weapon was discovered as well as all the files containing information on the transactions carried out for a given weapon. The combination of all this information with the technical elements would give the best possible chance of success for PT operations. Making use of the extrinsic elements however requires an overhaul of police records. For the moment, such a solution is hard to imagine, and quite difficult to implement on a large scale.

Furthermore, to improve tracing operations, each State must keep comprehensive records of all the weapons in circulation within its borders for an unlimited duration.

Each State must also facilitate exchange and transparency concerning weapons and develop a standardized tracing system. The study carried out by the UN²⁹ shows that tracing practices vary enormously from one country to another. These practices must be formalized and unified to improve the exchange of information and the rapidity with which it is processed. In the

case of Switzerland, it would be necessary initially to implement a uniform system in the various cantonal police forces and institutions. The use of statistics can also contribute useful data concerning weapon flows and trafficking and those involved in them. All the measures to which we have just referred require an effort on the part of everyone in order to propose a uniform, transparent and efficient system for tracing firearms.

Let us also recall the difficulty currently posed by weapons that do not bear durable and unique standardized marks. An interesting point to recall in this context is the manufacture of Kalashnikovs and of certain weapons by Smith & Wesson, which are a prime example of the problem of the serial number as an identifier. Prior to 1968, Smith & Wesson used identical serial numbers for different models of weapons; similarly, the same serial number can be found on several weapons of the same type when they are manufactured in different countries but under the same license; and finally, a manufacturer may periodically recommence the numbering of its weapons, as with Kalashnikovs and M-16s, for example.³⁰ One *sine qua non* condition for the tracing mechanism to function properly is to avoid the absence and/or duplication of serial numbers.

There is another point which it is important to highlight. Swiss legislation on firearms (“Recueil Systématique”—RS 514.54) contains certain loopholes that facilitate the disappearance of weapons and open the door to all sorts of fraudulent practice. Article 9, which deals with the acquisition of weapons by individuals, specifies that sales must take place in the context of a written contract that is valid for ten years. When these conditions are not complied with, the sale of a weapon by one individual to another perpetuates an uncontrollable grey market and creates many opportunities for fraud.³¹ How can weapons be traced in such circumstances? The law on arms therefore needs to be improved and legal standards compatible with the tracing mechanism such as we have defined it in this document must be proposed.

What is to be done, and how can the problem be resolved in a long-term perspective? What about the weapons-collecting operations that have been launched—without much success—and which have in fact had the adverse effect of “laundering” weapons previously involved in various conflicts?

There is no answer to the above, but conducting an evaluation does provide an idea of the outcome. In the context of perfect tracing, the solutions proposed would allow tracing operations to be improved considerably by providing innovative solutions. Since such a PT could not be considered a reasonably applicable solution, we must focus on other objectives. If we base ourselves on the pretty good tracing concept, taking into account only the technical elements such as the serial number allows firearms to be “partially” traced—many of them will slip through the cracks of such a mechanism. This is why a reasonable solution would be to integrate elements of forensic intelligence.

2.10 HIGH-TECH VERSUS LOW-TECH MARKING: SIGNIFICANT IMPLICATIONS FOR TRACING

The various points concerning the implications of the choice of the marking technique deserve to be discussed from several points of view: technical, financial and with regard to their feasibility. The decision as to the best marking technique depends a great deal on the related needs in terms of marking, registration and tracing for the different institutions and law enforcement agencies involved in this process, as well as on what is reasonably acceptable and feasible.

The principal technique currently used to mark firearms is stamping. It is a simple and inexpensive method, but one that has certain limitations as to the size of the mark, its location, and the deformation caused by the process. Moreover, the serial number is easily obliterated by milling, striking, gouging, drilling or double drilling. In comparison, marking by laser is a desirable alternative that allows the mark to meet the criteria for uniqueness, durability and invisibility. Let us also point out that laser marking also allows the weapon to be marked without any contact. The weapon can be marked on a limited surface area using various forms of codification such as bar codes, matrix codes or alphanumeric codes. From a technical point of view, the laser solution therefore appears to be the best choice.

Let us also mention marking methods that use chemical markers (as in the case of explosives) or electronic chips (similar to applications of

electronics in animal identification or electronic surveillance of products in supermarkets).

Smart guns, or so-called electronic weapons, are weapons that can be used only by authorized individuals wearing a corresponding transponder in the form of a ring or bracelet, for example. This is a first step towards the application of electronics to tracing weapons in the strict sense of the term. A first prototype of firearms with a transponder has been developed at the Institut de Police Scientifique et de Criminologie, Lausanne, Switzerland.

We have just briefly reviewed the different options for marking weapons. Depending on the technique chosen, several points will have to be discussed. The first concerns the cost of these techniques. The American example shows that the introduction of modern technology in the field of firearms is no simple matter. The cost of developing new technologies constitutes an obstacle to their application and their extended application to all the different weapons. Table 6 proposes an estimate of the cost associated with two different new marking techniques.

Generally speaking, the cost of establishing these new marking systems can be lowered depending on the number of items to be marked, and is neither technologically or financially prohibitive to their development in the near future. Nevertheless, *one* technique must be selected.

Table 6: Estimate of the costs of laser marking (centre column) and electronic marking (right-hand column) [Kullmann and Bui, private conversation, 2001]

Number of units to be marked	Unit price (CHF) ³²	Unit price (CHF)
10	34.70	---
50	7.50	---
100	4.10	---
1,000	1.05	7
5,000	0.75	---
10,000	0.70	4.50

Of course, the costs in Table 6 do not cover the expense of training personnel, developing reading methods or implementing the infrastructure required for the marking process. In order to limit costs, one good solution would be to use previously trained personnel and to seek the help of specialised industries. At this stage, it is a difficult and tricky task to come up with a figure for the costs necessary for the different operations involved in tracing, since certain parameters have not yet been chosen.

From the point of view of feasibility, the different methods that have been proposed are perfectly compatible with the tracing process such as it has been defined in this document. The choice now rests with political actors, who must define the method to be applied on the basis of the technical tools that have been proposed to them.

Let us also mention the problem of weapons currently on the market. Because of the considerable number of weapons and the impossibility of marking them all, it is imperative to concentrate first of all on those weapons that must be traced. The techniques proposed are compatible with old weapons as well as with those currently on the market.

Having broken down the process hierarchically has given us a better perspective of the different solutions possible. From the point of view of a PGT only, the technique of stamping does not allow all the parts of the firearm to be marked. Laser marking therefore appears to be a pertinent solution for our purposes. In the context of a PT, the use of electronic chips and replicated marking addresses the problem of obliterated serial numbers, as firearms can still be identified.

2.11 HOW COULD DIFFICULTIES BE BEST OVERCOME?

Throughout this document, we have listed a series of arguments relating to marking and tracing firearms. We have highlighted a certain number of problems that may be encountered during the elaboration of this process. In order to avoid these difficulties inasmuch as possible, several points should be discussed.

First of all, it is important to note that tracing operations are not feasible in the short term. Quite some time may pass before the measures adopted are applied. The tracing process is a long-term one. Moreover, we have

based on our reflection on goals for the tracing process—the PT and the PGT, each of which requires the application of more or less technical and innovative solutions.

Better management of the registers kept by law enforcement bodies and national and international cooperation should in turn allow the flow of information to be better managed in order to provide a clearer picture of the criminal element and to facilitate the exchange of information. Each State should contribute to obtaining a certain degree of transparency regarding weapons, at both the national (for example, Switzerland and its federal pluralism) and the international levels.

The adoption of uniform marking should facilitate the exchange of data and allow law enforcement agents to optimize the various tracing operations. As for marking, other States could borrow from the Swiss experience and the different prototypes that have been developed and presented.

The second step consists in agreeing on the marking content and method with a view to harmonizing the practices of the various manufacturers. The same reasoning can be applied to the problem of registration. Here it is important to recall the few points that require an effort in order to form a better picture of the global tracing process:

- redefinition of weapons from a technical point of view, and adoption of precise terminology that avoids over-generalization;
- development of a tracing system for particular weapons (tanks, missile launchers, etc.);
- encouragement of States to cooperate with one another and with arms manufacturers and technical experts;
- analysis of the available data in order to provide a clearer picture of the weapons involved in armed conflict and crime;
- identification of the weapons to be traced; this operation will also enable the perpetrators to be identified;
- use of the experiences of other countries as inspiration to develop and make operational a global tracing process;
- a centralized organ is apparently difficult to conceive of; each State must therefore be able to carry out trace operations at the national level.

In conclusion, let us recall that the rapid and efficient processing of information determines the success of police action. This is why it is important to establish a tracing mechanism that allows all these requirements to be satisfied.

In this context, the development of new software enabling extrinsic (forensic intelligence) elements to be taken into account would take too much time. In the PGT context, collecting and analyzing existing data should allow tracing operations to be improved considerably. For this reason the development of study programmes that allow the data currently present in the various national registers to be identified and analysed is strongly encouraged. A study to this effect is currently being carried out in Switzerland.

Notes

- ¹ K. Kramer, *Legal Controls on Small Arms and Light Weapons in Southeast Asia*, Occasional Paper No. 3, Small Arms Survey and Nonviolence International Southeast Asia, 2001.
- ² A. Gallusser, M. Bonfanti and F. Schütz, *L'expertise des armes à feu et des éléments de munitions dans l'investigation criminelle*, Presses polytechniques et universitaires romandes, Lausanne, Switzerland, 2002.
- ³ *Le Petit Larousse illustré*, dictionnaire de la langue française, Larousse, Bordas, Paris, France, 1998.
- ⁴ The World Forum on the Future of Sport Shooting Activities, *Defining "Small Arms" as they Pertain to "Firearms" for the 2001 UN Conference on Small Arms*, Workshop, London, United Kingdom, 2001.
- ⁵ Ibid.
- ⁶ K. Kramer, op. cit. note 1.
- ⁷ P. George, "Analyse criminelle : recherche d'une logique derrière la criminalité", *Politeia* (1), pp. 19-25, 1996.
- ⁸ J.P. Greco, *Pattern Crimes—Firearms Trafficking Enforcement Techniques*, US Department of Justice, Federal Bureau of Investigation, 1998.
- ⁹ L. Axon and S. Moyer, *Etude exploratoire de l'utilisation d'armes à feu dans la perpétration d'infractions criminelles à Toronto*, Ministère de la Justice du Canada, 1994.

- ¹⁰ Small Arms Survey, *Annuaire sur les armes légères 2001 – Gros plan sur la problématique*, Groupe de Recherche et d'Information sur la Paix et la Sécurité (GRIP), Bruxelles, Belgique, 2001.
- ¹¹ S. Jorion and P. Regenstreif, *Culots de munitions, Atlas, Tomes I et II*, Cépaduès Editions, Toulouse, France, 1994.
- ¹² United Nations Organization, *Recommendations on the Transport of Dangerous Goods—Model Regulations*, 11th edition (ST/SG/AC.10/1Rev.11), New York and Geneva, 1999.
- ¹³ F. Schütz, “Serial Number Engraved by Laser: A Preliminary Study”, *AFTE Journal*, 33(3), pp. 280-281, 2001; and K. von Wolf, “Big Brother, Registrierungspflicht für Munition”, *Deutsches Waffen Journal* (4), pp. 36-37, 2001.
- ¹⁴ Quoted from the Swiss daily newspaper *24 heures*, 5-6 January 2002, p. 3.
- ¹⁵ J.P. Greco, op. cit. note 8.
- ¹⁶ Centre Canadien des armes à feu, “Armes à feu récupérées par la police : étude de sites multiples”, Daniel Antonowicz Consulting, 1997b.
- ¹⁷ Centre Canadien des armes à feu, *L'utilisation des armes à feu dans les affaires d'homicide, de vol qualifié et de suicide sur lesquelles le service de police de Winnipeg a fait l'enquête*, 1997a (http://armeafeucanada.com/research/publications/reports/1997/reports/winn_rpt_fr.html).
- ¹⁸ Centre Canadien des armes à feu, op. cit. note 16.
- ¹⁹ Berkol, I., *Marquage et traçage des armes légères – vers l'amélioration de la transparence et du contrôle*, Groupe de Recherche et d'Information sur la Paix et la Sécurité, Bruxelles, Belgique, 2000.
- ²⁰ D.B. Kopel, *Clueless: The Misuse of BATF Firearms Tracing Data*, 1998 (<http://www.i2i.org/SuptDocs/Crime/LawReviews/CluelessBATFtracing.htm>).
- ²¹ B. Davey, “Glock Information”, *AFTE Journal*, 24(4), p. 314, 1992.
- ²² Bureau of Alcohol Tobacco and Firearms (BATF), *Firearms & Explosives Tracing*, Department of the Treasury, Landover, Maryland, US, 1988.
- ²³ D.B. Kopel, op. cit. note 20.
- ²⁴ Small Arms Survey, op. cit. note 10, p. 94.
- ²⁵ L. Axon and S. Moyer, op. cit. note 9.
- ²⁶ D.B. Kopel, op. cit. note 20.
- ²⁷ Small Arms Survey, op. cit. note 10, p. 49.
- ²⁸ J.P. Greco, op. cit. note 8.

- ²⁹ Organisation des Nations Unies, *Enquête internationale sur la réglementation des armes à feu*, Publication des Nations Unies, New York, US, 1998.
- ³⁰ I. Berkol, *L'importance de la traçabilité des armes légères*, exposé lors de l'audition par la Commission des relations extérieures du Sénat dans le cadre de l'examen de la Proposition de loi sur le marquage des armes légères et de petit calibre, munitions et explosifs, Bruxelles, Belgique, 2002.
- ³¹ J.-F. Hugentobler, "Des armes et des drames", *Femina* (44), pp. 16-18, 2000.
- ³² Euro 1 = CHF 1,50 (estimate May 2002).

APPENDIX 1

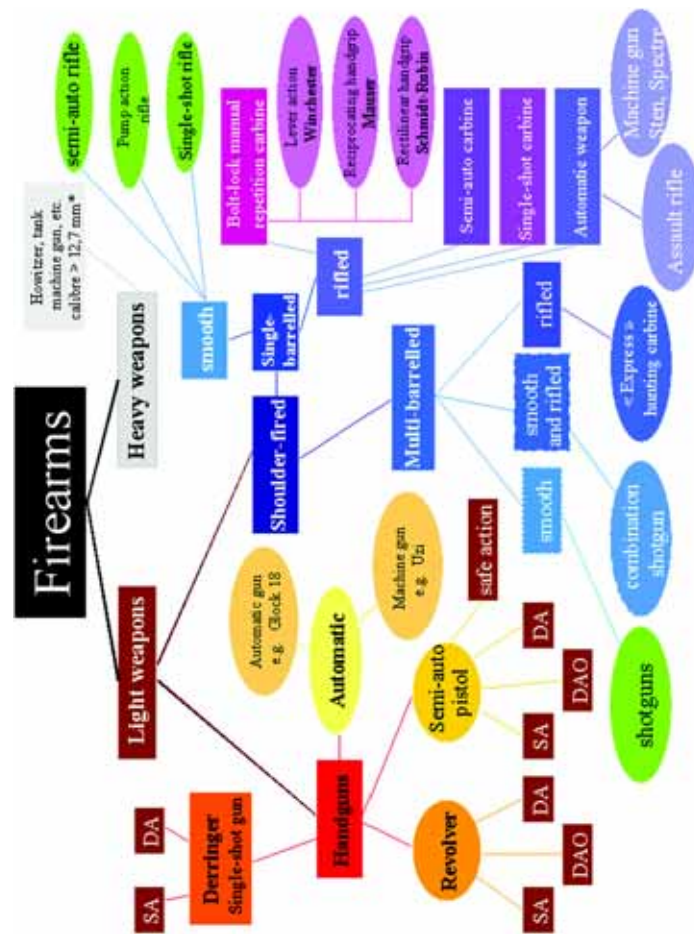

APPENDIX 2

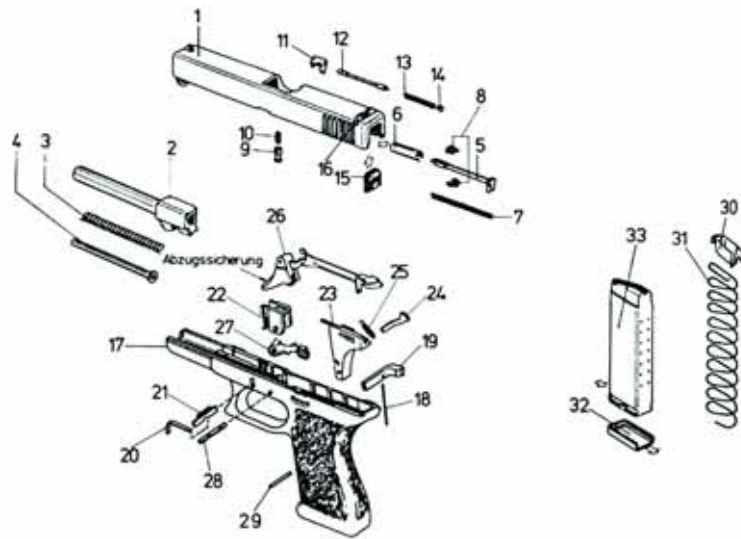

APPENDIX 3

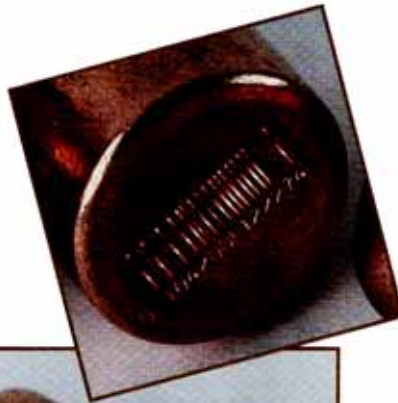

APPENDIX 4

D'où vient l'arme du crime?

FASS 90 L'enquête dira si le fusil utilisé est une arme d'ordonnance ou si elle vient du commerce.

Le forfait a été perpétré avec un fusil d'assaut 90, de calibre 5,56 millimètres. C'est celui qui équipe l'armée suisse. C'est également celui qu'avait employé le forcené de Zoug le 27 septembre dernier. Mais pour l'instant, impossible de savoir si l'arme du crime est une arme d'ordonnance ou si elle a été achetée dans le commerce. «Un détail les différencie: la version de l'armée peut tirer en rafale alors que celle vendue dans les armureries peut seulement faire du coup par coup», précise Claude Perret, chef du Bureau des armes de la police cantonale vaudoise.

Quelle que soit sa provenance, on n'achète pas un Fass 90 aussi facilement qu'une pelle à charbon. Il faut déboursier quelque 2500 francs et surtout montrer patte blanche: permis de port d'armes, extrait de casier judiciaire et

permis d'achat délivré par la police sont, entre autres, nécessaires. Quant aux personnes astreintes au service militaire, autrement dit celles qui ont un Fass 90 chez elles, pas question de s'en servir pour aller chasser le sanglier. La munition est conditionnée dans une boîte scellée qui doit être présentée en l'état lors de chaque inspection. «On a beau mettre en place des garde-fous, ce n'est pas tou-

jours évident d'empêcher les fous de les franchir», rappelle avec une once de fatalisme Claude Gerbex, porte-parole du Département fédéral de la défense, de la protection de la population et des sports (DDPS). Avant d'ajouter que «l'utilisation des armes d'ordonnance pour commettre des crimes est rare. Tellement rare qu'aucune statistique n'existe à ce sujet.»

Sylvie Ulmann



Le tireur a utilisé un Fass 90, un fusil qui équipe l'armée suisse.
Patrick Martin

Where does the weapon used in the crime come from?

FASS 90—The investigation will determine whether the rifle is army-issued or store-bought

The act was committed with a 90-model, 5.56 mm-calibre assault rifle. This is the same weapon used to equip the Swiss army. It is also the same gun used by the maniac in Zug on September 27 last. But for now, it is unknown whether the weapon used in the crime was issued by the army or bought in a store. According to Claude Perret, head of the arms bureau of the Vaud Cantonal Police, "There is one small distinguishing feature between them:

the army weapon is capable of automatic fire while the commercially available version can only fire one shot at a time”.

No matter what its origin, purchasing a Fass 90 is not as easy as buying a pack of cigarettes. The purchaser must fork over 2,500 francs and, more importantly, must possess a spotless record: a gun permit, clean police record and a purchase permit issued by the police are among the necessary formalities. Otherwise, those active in military service, or in other words who have a Fass 90 at home, cannot simply succumb to an urge to go boar hunting with it. The ammunition is packaged in a sealed box that must be presented unbroken each time the individual reports to the army. “We can always implement safeguards,” says Claude Gerbex, spokesman for the Federal Department of Defence, Civilian Protection, and Sports (DDPS), somewhat fatalistically “but it is not always easy to stop madmen from eluding them.” He adds, “The use of military weapons to commit crimes is so rare, in fact, that there are not even any statistics on the subject.”

Caption: The gunman used a Fass 90, the rifle used by the Swiss army.
Patrick Martin

Taken from the Swiss daily newspaper *24 heures*, 21 February 2002, p. 17.

CHAPTER 3

MARKING AND RECORD-KEEPING SYSTEMS AND MODALITIES OF OPERATION

Michael Hallowes^{*1}

This paper reviews specific aspects of the legal arms trade and assesses the potential to utilize law enforcement and intelligence networks in an arms control context to enhance existing measures to counter diversion and illicit trafficking. It has not been possible within the time constraints to broaden the research beyond those mentioned in this paper.

3.1 THE DIFFERENT KINDS OF MARKING AND RECORD-KEEPING SYSTEMS NEEDED TO SUPPORT A TRACING MECHANISM

3.1.1 Existing Marking Methodology

There have been numerous studies on different marking modalities but the traditional method of stamping the unique identifier remains the most efficient and effective for individually marking military small arms and light weapons (SALW) and their essential component parts. Marking should be on the frame or receiver as this is the primary structural component to which all others are attached. Small arms manufacturers worldwide tend to favour stamping, as it provides a simple, robust and cost effective means of marking.

With regard to ammunition, head-stamping the cartridge case is the traditional method of marking each round using a mixture of letters, numbers and symbols to identify them. Markings vary together with their

* The views expressed in this paper are those of the author and do not necessarily reflect UK Government policy.

significance, hence in general terms the marks can include the manufacturer, calibre, date and batch code, as demonstrated below with these 0.50" calibre rounds on the left. Alternatives, as shown to the right of the picture on this 40mm grenade, can include printing information on the side of the cartridge case. Markings are not intended to be unique to each round due to the disproportionate cost involved and lack of any commercial benefit for doing so. Instead ammunition is marked in batches that can range from 1000s to hundreds of 1000s. Additional marks are used on the external packaging, where there is more space to provide information, to identify the manufacturer, country of origin, calibre, date and quantity. Supplementary marks can be added to the packaging by importing countries but corresponding import marks are not added to the individual rounds. Consequently, the ability to effectively trace the history of ammunition when it has been separated from its packaging is severely limited.



From a forensic perspective, the benefit to law enforcement agencies of stamping over other less intrusive methods, such as engraving and etching, is that the depth of disruption to the molecular structure of the metal involved in stamping means there is a greater opportunity to retrieve some if not all the details should an attempt be made to obliterate the mark. Mindful of this point, new legislation in South Africa, for example, requires all new firearm markings to be stamped.

The use of laser etching, for example, to create secondary, duplicate or covert marks in generally inaccessible places is a concept that has been previously discussed at UN sponsored meetings in Geneva, as well as by the arms manufacturers represented on the World Forum for Sport Shooting Associations (WFSA) at their meetings in Brescia and Sardinia. Covert

secondary marking is certainly a concept worth developing to enhance the tracing potential.

Another aspect being considered involves marking on critical areas of a weapon where any attempt to obliterate the mark will lead to structural failure rendering the weapon inoperable. For example, the Swiss arms manufacturer, SIG, recently introduced laser etching to provide covert secondary marks on their handguns. These include marking the serial number on to the firing pin and a barcode on the extractor.

One of the leading marking regimes can be found in South Africa. South African legislation currently requires all firearms to be marked with a combination of **make, model, calibre, country of manufacture** and **serial number** to create a readily identifiable unique set of markings clearly stamped on a high-stress metal part of the weapon. Weapons produced for the commercial market (civilian or military export) are then recorded in the Central Firearms Register (CFR), whereas those produced for the South African National Defense Force (SANDF) are held on a separate, independent military database. South African arms manufacturers coordinate with the CFR and SANDF to ensure that markings on newly produced weapons do not duplicate with those already held on the national systems. Where markings on an imported weapon are found to duplicate those already recorded on either the CFR or SANDF databases, the authorities will stamp either a completely new replacement marking or, as is normally the case, prefix the existing serial number with the letters "WR" ("Wapen Register"). Both methods ensure that the marking is internationally unique.

However, South Africa is moving towards further improvements with the introduction, on 1 January 2003, of an internationally unique alphanumeric serial number for all new weapons produced, which will be similar to the existing UK Ministry of Defence regime. The advantage of this new approach is that it no longer relies on marking combinations, which in turn overcomes the obvious difficulties of trying to differentiate between the wide varieties of model types produced by manufacturers. The South African arms industry will mark each new weapon with a code indicating, **Country of manufacture** (in this case ZA), **Year of manufacture**, and **Serial number** as follows: **ZA 02 234567**. This method of unique identification is immediately user-friendly for identification, record-keeping and, consequently, cross-border tracing.

3.1.2 Sanitization

Removal or obliteration of identifying marks is commonly referred to as “sanitization”. Across the illicit small arms market, sanitization is still not generally widespread. Diversion from legal to illicit market is often a deliberately lengthy and contrived process, sometimes involving “front companies” set up for a one-off transaction, which means that, even though it is still possible to trace and attribute weapons back to the actual point of diversion or source, by the time investigators have traced the weapons back, the individuals concerned have closed their business and moved on. Therefore, sanitization may not always be necessary. In conflict zones worldwide, it is commonplace for weapons to be recycled and to circulate between rival factions criss-crossing borders, which further negates the need to sanitize marks. There are other factors, which can impact on the need to sanitize, and these include, the quantity of weapons involved; whether the weapons are second-hand, and the level of political or commercial damage tracing would have. The latter is a major consideration for State-controlled arms industries (including those in which local politicians have a vested interest) supplying new or surplus ex-military weapons from official government stocks.

However, in the criminal handgun market, for example, sanitization occurs more frequently; approximately 20% of illegal handguns recovered in the UK have been sanitized. The diversion process from legal to criminal market is much shorter, often sourced direct from a limited number of dishonest registered firearms dealer. A comparison can be made, though, to small arms where a “rogue State” may sponsor an illicit supply of arms, in which case sanitization will be an important consideration.

Intelligence sources suggest that there has been an increase in sanitization commensurate with tracing activities of UN and NATO Forces. It has become a feature of the long-term peacekeeping role of KFOR in Kosovo, for example, to identify the sources of illicit weapons and thus disrupt supplies to disarmed combatants.

Illicit traffickers are alive to the threat tracing poses to their activities. Hence, while sanitization is currently not widespread it is likely to grow as traffickers try to counter the increasing emphasis amongst UN, NATO and Organization for Security and Co-operation in Europe (OSCE) countries, spurred on by the NGO community, to identify sources of illicit weapons.

It is unnecessary to sanitize markings on ammunition due to the large numbers in each batch that bear identical marks, and these batches can then be split between several subsequent buyers and then separated from their packaging to further frustrate tracing.

3.1.3 Content of Markings

The content of markings vary greatly but in general terms, there are three principle methods.

(i) *Alphanumeric Code*

The UK, for example, relies on a unique identifier using a simple alphanumeric code individual to each weapon regardless of its type.



British SA80 Rifle

Unique Identifier: UE 85 A000001

U = Code for Country of Manufacture—UK
E = British Factory Code = **Enfield** (N = **Nottingham**)
85 = Year of Manufacture—1985
A000001 = Serial No.

(ii) *Combination of Alphanumeric Code with Symbols*

China, Russia, and many former Eastern Bloc countries use a combination of numbers, letters and symbols to uniquely identify their weapons. This more complex system is used by China to overcome the difficulty where a number of factories simultaneously produce identical weapons with duplicate serial numbers and it is only when the individual factory symbol is added to the serial number, etc. that the marking becomes unique. The country of manufacture is rarely included, which means correct identification and then tracing is wholly reliant at the outset on experts correctly recognizing the significance of specific features and markings.



Chinese Type 56-1

Unique Identifier:  **56-1 26 019585**



= **Chinese Factory Symbol**

56 - 1 = **Type**

26 = **Code from which the Year of Manufacture can be calculated (1967)**

019585 = **Serial No.**

(iii) Combination of Alphanumeric Code or Serial Number plus Manufacturer, Model and Calibre

The US uses a combination of Manufacturer, Model, Calibre and Alphanumeric Code or Serial Number to create the unique identifier. However, difficulties with identification can arise where the marks are not necessarily adjacent to each other. On its own, the serial number may not be unique, so it is vital that all the elements are included to ensure each weapon is accurately and individually identified.



US Colt M16



Unique Identifier:

COLT = **Manufacturer**

M16 A2 = **Model**

CAL. 5.56MM. = **Calibre**

819518 = **Serial Number**

-USA- = **Country**

Serial number sequences change each year to identify the year of manufacture.

3.1.4 Markings on Components and Spare Parts

A partial number, if not the complete mark, can be used for component parts using elements of the full marking on the frame or receiver. It has been a common standard for component parts, such as barrels, to be marked with just the alphanumeric component of the unique identifier. This originates from the production line where manufacturers need to ensure that components machined for a specific weapon are not mixed with those made to fit another.

A high degree of specialist knowledge is required, therefore, to identify component parts when separated from the complete weapon. One method to enhance the potential for tracing is to use an alphanumeric code from which the manufacturer, country of origin, year of manufacture and a unique serial number can be identified. There are estimated to be some 600 arms manufacturing companies worldwide. Borrowing from the automotive industry, which uses simple alphanumeric codes to mark their components, a mix of three letters would provide sufficient variations to create a range of codes (17,576) unique to each manufacturer and then seven or more random numbers would create a year and unique identifier for each replacement part they produce. For example, **W A U 9 9 1 7 1 1 8**

W A U	= Audi (Ingolstadt factory in Germany)
9 9	= Year of manufacture
1 7 1 1 8	= Serial number

3.1.5 Marking on Import

Many countries require imported small arms to be additionally marked with the individual ordnance mark for that country or, as in the case of civilian firearms, the importer's name and address or logo. Proof marks are also a means of marking on import.

For new weapons produced for a specific export market, legislation in the US for example, allows the importer's details to be marked at the time of manufacture in the exporting country. This reduces costs and overcomes the problem that subsequent import marks may damage the protective finish. However, there are risks involved in the event that the weapons are stolen or diverted prior to reaching their intended market. Consequently, other countries, such as South Africa, use import marking as a means to

verify that the imported weapons arrived in their jurisdiction. The South African system coordinates import marking with record-keeping and, therefore, takes place before final delivery to the importer.

As an outcome of negotiations on the UN Firearms Protocol, EU member States are considering the use of national import marks, which will be applied upon first import into the Community identifying the country and year of first import. Intra-EU transfers thereafter will not require additional import marks and tracing and tracking will be reliant on accurate records being kept in the transferring States. Permanent export from the EU and subsequent re-import will require a new import mark, whereas temporary cross-border transfers (sport shooters, hunters, trade fairs, etc.) will not require any additional markings. The mark will be the same size as those used for Proof stamping. (Proof Mark approximate size )

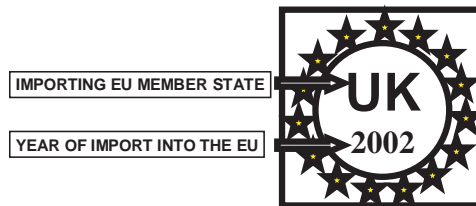

Thirteen countries² are members of the Commission of International Proof (CIP). CIP Regulations require all firearms and military small arms (manufactured or imported within a CIP jurisdiction) to be submitted for safety testing and to be stamped with verification marks prior to use, sale or export. CIP marks include a national stamp and year code, which can be exploited in tracing enquiries.

Import marking is a useful means of overcoming difficulties where the numbers, alphabet or symbols used by the manufacturer are not compatible with record-keeping systems in the importing country, such as the examples shown below.



In such cases, a new unique identifier can be applied on each weapon to replace the original. For example, all imported military small arms issued to the British armed forces are given a replacement mark (regardless of the original manufacturer's marks), and the following is provided as an illustration:



B = Code for Country of Manufacture—Belgium
L = UK Import Code
88 = Year of Import—1988
A000001 = Serial No.

(Proof Marks are added if the weapon originates from a non-CIP country).

For the purposes of record-keeping in the UK, the import marks replace those of the manufacturer's.

There is a practice amongst some small arms manufacturers, for example Fabrique Nationale (FN) Herstal, Belgium, to allow finished weapons to leave the factory without any identifying marks. These weapons are manufactured for a particular export market where the importing country wishes to use its own marking system exclusively to identify the

weapons. There are risks involved should individual weapons or the whole consignment be stolen whilst in transit. It would be timely to encourage a review of the practice of exporting unmarked small arms and introduce a unique manufacturer's identifier marked on each weapon (in a discreet location if not to be immediately visible) and in accordance with Article 8 of the UN Firearms Protocol.

3.1.6 Additional Marks which Aid Identification

There are a wide variety of supplementary marks used on military small arms and light weapons which may not uniquely identify an individual weapon but, nevertheless, play an important part in helping to trace the origin or previous market, particularly when serial numbers, etc. have been sanitized. These marks can include those shown here:

<p>Import Mark Proof Mark Year or Batch code [Marked on the frame]</p>	
<p>Armourer's marks [Marked on the furniture]</p>	
<p>Selector markings [Adjacent to the trigger]</p>	

Individually these supplementary marks are not unique but a combination can be almost as good as a fingerprint for identifying the history of a weapon and its potential source, particularly where they can be linked to previously seized weapons whose origins have already been traced. Traffickers very often overlook these features when sanitizing weapons and, hence, it is important to exploit the intelligence they provide.

Proof marks, Import and Importers' marks are cross-referenced with additional records held by the relevant authorities, which can be utilized in

the tracing process. For example, a British Proof Mark will identify which of the two Proof Houses, Birmingham or London, inspected the weapon and the year. Every inspection is recorded on computer to include the following details:

Manufacturer and Country of origin;
Type/model and Calibre;
Serial No./unique identifier;
Importer or arms dealer;
Dates of import and/or submission; and
Other weapons in the consignment.

Systems for recording stocks of military small arms do not necessarily need to include this level of detail. What is required, however, is that adequate records are held elsewhere by the relevant importers, Proof Houses and Regimental Armourers. It is important that the use, meaning and relevance of all supplementary markings are made available to law enforcement and intelligence agencies to assist in the identification and tracing process. For example, the British Proof Authorities (BPA), together with the other 12 CIP members, provide ready access to their computerized archives.

3.1.7 Correct Identification of Weapons and Markings

Correct identification of the weapon is vital. Problems arise when a number of countries mass produce similar model weapons copied or manufactured under licence from an original design, such as the Russian AK-47 “Kalashnikov” assault rifle, which has since been manufactured in as many as 19 different countries, and some of these are shown below to illustrate the problem. (None of these are marked with the name of the country of manufacture).

China Type 56-1



East Germany AKM



China Type 56



Russia AK47



Russia AKS47



Bulgaria AK47



Russia AK74



Poland AKSU



Similarly, correct identification of all the elements which make up the complete unique marking for any weapon is critical but requires a high degree of specialist knowledge, and it is impractical to train all law enforcement and military personnel to this level. Hence training has to be limited to a small number of experts within a central agency for each country or region and access to their expertise by personnel in the field can be readily achieved using secure Internet channels.

To add to the problems of investigators, there are a limited number of arms manufacturers that produce either counterfeit copies or falsify markings to match those of another manufacturer. One reason is to increase sales by making their inferior weapons resemble those made by the world's leading manufacturers. For example, the firearms shown below are manufactured in a particular East European country as HS 95 model handguns falsely marked as "SIG Sauer" and "Smith and Wesson" pistols. They bear some resemblance to the real weapon, but any police or military

official recovering these weapons without any knowledge of such counterfeits, would assume the markings to be genuine and initiate an entirely flawed tracing enquiry with SIG or Smith and Wesson wasting valuable time and resources. Correct identification requires additional expertise to differentiate between genuine and counterfeit arms.



To overcome difficulties in weapon and marking identification, the Royal Canadian Mounted Police (RCMP) created a photographic database, known as the Firearms Reference Table (FRT), cataloguing in excess of 22,000 firearms, military small arms and light weapons. The FRT is regularly updated to meet its primary uses: one, to assist police officers in the field to correctly identify weapons submitted for registration on the Canadian Firearms Register and two, to identify and trace recovered illicit weapons. Remote access to the system is made via secure Internet channels, which enable police officers to make on-line comparisons between the weapon being examined and the FRT catalogue. This procedure ensures that first, weapons are correctly identified and second, the markings needed to create a unique record or begin a trace are accurately noted. This innovative system is fundamental to maintaining the integrity of the Canadian National Firearms Register.

The FRT is also a pivotal element of the Interpol International Weapons and Explosives Tracking System (IWETS). IWETS is the mechanism by which countries can exchange information to trace recovered firearms used in crime. It can also hold details of every lost or stolen firearm (or military small arm). The system is being radically upgraded to include the very latest technology and rollout is expected within the next 12 months. Initially, access will be limited to each National Contact Bureau (NCB) for the 179 Interpol member States. Communication will be via secure Internet

channels, with the protection of encryption codes, and controlled by individual User Names and Passwords.

Whilst IWETS will be primarily a law enforcement tool, other agencies are exploring its benefits in the context of arms control for tracing illicit small arms and prosecuting and disrupting the traffickers. Therefore, provided law enforcement and/or criminal justice criteria are met, Interpol and IWETS would provide the ideal model for future tracing activities involving illicitly trafficked military small arms and light weapons. IWETS has the added attraction of being an off-the-shelf product supported by the Interpol network linked to law enforcement agencies worldwide, so there is no need for the UN to replicate the system for its peacekeeping forces. Instead, protocols need to be agreed between the UN and Interpol to enable access via local law enforcement agencies.

3.1.8 Record-Keeping

Record-keeping for military small arms and light weapons varies enormously between State authorities worldwide. Currently, the lowest level involves manual paper-based systems. Computerization has to become the international minimum standard. Tracing the history of particular small arms through several markets becomes prohibitive if each stage of the search relies on a manual trawl through paper records. Hence, manual systems need to be rapidly upgraded to computerized databases in order to expedite tracing requests, as well as adding benefit to stock control and security measures. Consideration needs to be given to the degree of back record conversion needed to facilitate tracing enquiries for which 32 years would be an appropriate period for military weapons.

Record-keeping systems need to build in a fast track mechanism for tracing requests to support the imperative of early intervention and prevent the continuing threat to life posed by traffickers.

The US, UK, Australia, South Africa and Canada, amongst many others, have sophisticated military-owned computer databases providing a centralized national record of each individual weapon in use and the regiment to which it has been allocated plus the quantity and calibre of ammunition supplied. These are kept separate from the civilian licensing and registration systems and access to records by law enforcement agencies is restricted on a case-by-case basis to trace specific weapons. The

computer programmes are available as off the shelf products, which can be adapted to suit the needs of other countries wishing to avoid the costs of their own research and development.

Costs can also be shared if a regional approach is taken. The new Central Firearms Register developed in South Africa, for example, has been designed so that it can be extended to cover other countries in Southern Africa. In Africa, only South Africa, and to lesser extent Zimbabwe, have an arms manufacturing industry. Thus the record-keeping system envisaged for the other countries in the region will be relatively simple, relying solely on import declarations.

For reasons of ease of access, as well as the economic benefits, information on the commercial arms trade should be kept centrally by one national agency. Similarly, records of all weapons issued to the military should be centrally held by one defence agency. Both should be held on computer databases to speed the process of tracing and tracking. Nevertheless, in the case of individual military units, paper still has a place for recording day-to-day information, such as the issue and return of weapons and ammunition.

Work is needed to close a worldwide gap in maintaining accurate records for those weapons that use a symbol as an essential element of the unique identifier. Currently, there is a wealth of information on these symbols held in a variety of books, but no database. It would be most helpful if these symbols could now be computerized into a database, involving tables with drop-down menus categorized by triangles, circles, etc., similar to Microsoft Word "Wingdings". This would allow for much greater accuracy, not only for record-keeping but also with tracing. Certainly those involved in the current stock-taking of military small arms in Albania, for example, would find such a table a great asset for computerizing the back-record conversion of the thousands of weapons held. Similarly, Interpol would benefit from introducing such a "Symbols Database" to their design for IWETS. What is needed now is for a number of interested parties to come together and commission work to create the "Symbols Database", potentially, on a CD Rom that can then be shared with Military and Law Enforcement Agencies worldwide to enhance their record-keeping and tracing activities.

3.1.9 Comments

Countries seeking to introduce record-keeping linked to a new licensing and registration regime might consider that they should begin with, what appears on the surface to be, a cheaper manual paper based system and then gradually evolve into a computerized database. However, this can be a false economy as considerable costs will be involved in the subsequent back-record conversion and validating the original entries. In addition, national law enforcement agencies will spend costly man-hours trawling through paper records and making numerous personal visits to carry out physical inspections in order to complete each tracing request. These are the hidden costs of paper systems. Such costs do not exist when the same searches can be conducted remotely in a matter of minutes using a central computerized national register.

Recognizing these points, when Canada introduced civilian firearms registration in the late 1990s, it chose to start from scratch using computerization. Published start-up costs for the Canadian Firearms Register (CFR) quoted a figure of US\$ 60 million. However, with 3.5 million gun owners being charged US\$ 12 to register their 6 million firearms, these revenues helped recover some of that, but continuing expenditure has greatly increased the overall costs. Computerization was essential to streamline the process and, with built-in national data standards, “error rates” could be minimized. Registration used a bespoke computer programme, called the Firearms Registration Direct Entry System (FREDES) and, with a cross-reference to the FRT, validation checks were completed at the point of entry. The next generation involves cheaper web-based registration utilizing an on-line connection to the national Register. Now that the CFR is firmly established, updating the computer records is a straightforward process requiring a limited number of permanent staff to supervise the process. The additional benefits of the CFR database are that the system of mandatory disclosures provides a capability to monitor activity in real time to proactively identify suspicious transactions. In addition, tracing enquiries are automated enabling both the restoration of recovered stolen firearms to their owners and the identification of points of diversion for weapons recovered used in crime.

The computer programmes developed for the CFR are available as off-the-shelf products, which other countries can purchase to avoid the expense of their own costly research and development. Start-up costs can,

therefore, be greatly reduced to much less than the US\$ 60 million involved in the design of the Canadian CFR. For example, 14 of the African countries, which signed up to Bamako Agreement, are presently considering the purchase of FREDES and the FRT³ to support their new civilian firearms registration programmes.

Countries do not necessarily need to build systems as technically advanced or as expensive as the Canadian Register. For example, when South Africa first introduced their computerized Central Firearms Register (CFR) it spent US\$ 2.1 million each year on administration. An enhanced system is being phased in at a cost of US\$ 19 million spread over three years with an annual budget of US\$ 6.4 million to administer. Licence fees have been increased to balance the higher costs. The CFR employs around 350 people.

As a further example, the UK Interpol National Contact Bureau (NCB) undertakes less than 1,000 tracing enquiries annually. The annual budget is less than US\$ 1 million and employs just four permanent staff and, when not involved in tracing, these staff are available for other tasks within the NCB.

National centralized systems are more advantageous than regional ones. Tracing on a national scale using regional systems can lead to the request being routed through each individual region to check whether the country has any record of a particular weapon. For example, the UK used to operate regional systems for its national records of licensed dealers and private owners. The chief officer for each of the 52 regional police forces independently maintained their own system and there was no opportunity to cross-reference their records. Consequently, it became possible for rogue arms dealers to hide their diversion activities by registering sales to non-existent companies that were "located" outside the jurisdiction of their local police record-keeping system. The introduction of a national database linking each of the 52 regional systems has minimized the opportunity for fraud.

It is also important to link details of the weapons held by individuals and commercial dealers to their licensing records, so that it is possible to identify precisely what weapons each civilian owner or dealer holds and, again, these need to be computerized. Where such records do not exist, for police to trace a weapon will involve officers having to personally visit each individual concerned in the chain of ownership to inspect their records and,

as a result, potentially tip-off the dishonest dealer. This manual process is prohibitively time consuming involving disproportionate costs, which is why in the UK, historically, tracing was undertaken in only 6% of cases. However, the UK is still without a computerized database listing individual civilian and commercial firearm holdings. Nevertheless, proposal for a National Firearms Database include an important link to the Police National Computer, as it has been recognized that record-keeping cannot stand alone and has to be integrated with other national intelligence databases to detect, for example, fraudulent applications for firearm ownership.

In 2001, the US Bureau of Alcohol Tobacco and Firearms undertook 240,000 tracing enquiries. However, this does not represent the total number of illicit firearm recoveries investigated in the US. In many countries tracing is not a routine aspect of investigations involving illicit firearms. There are a number of factors that influence this: one is the cost (including time) and another is the fact that tracing can complicate the original investigation, especially where identifying the history of a weapon does not form an essential part of the evidence to prove the case. For example, in a case involving an armed robbery, the prosecution will rely on evidence to show that the person arrested was in possession of an unauthorized firearm. Tracing is, therefore, irrelevant to the case and will not be undertaken. Many investigators need to be re-educated in the importance of tracing. Individual recoveries may not have any significance at the local level but, when analysed alongside others on a national or regional level, the bigger picture becomes apparent as individual seizures become linked to batches of identical weapons.

In 2003 the UK will introduce the computerized National Firearms Forensics Intelligence Database (NFFID). Seized illicit weapons will be forensically cross-matched, for example, through serial numbers from the same batch or identical hallmarks involving the same gunsmith, to identify common denominators that link them to one illicit source. When linked to tracing, the NFFID will provide valuable intelligence linking a multitude of individual seizures, potentially missed at the local level, to a much larger illicit trafficking operation. Therefore, law enforcement agencies need to view tracing at the strategic level to prevent illicit trafficking.

There is a widely held axiom that potentially every illegally held firearm was once in lawful circulation and, therefore, transfer to the illicit "black market" involved a diversion from the legal market. Consequently,

whenever illicit weapons are recovered, it is essential to use tracing to identify the point of diversion. Whilst individual investigators may consider tracing irrelevant to their case, on a national scale it is vital that a central agency takes control to prevent an accumulation of destabilising illicit weapons proliferating amongst criminal groups. To counter the criminal arms trade, a central agency needs to gather information about all illicit firearm recoveries from around the country, or from a group of countries, and conduct separate tracing enquiries. There are big gains to be had, for example, where one weapon is traced to a source other weapons may well be identified. The source of illicit supply can then be dismantled and further weapons prevented from entering the “black market”. It is hoped that the next generation of IWETS, the Interpol International Weapons and Explosives Tracking System, will include an analytical function capable of this task.

In view of the potential for leakage from the legal market, it is essential that the business activities of commercial arms dealers are scrutinized, which includes random visits by police and customs officials to verify that their registers and stocks tally with the disclosures made to the national record-keeping system.

With regard to tracing, it is not always necessary to trace every weapon recovered, particularly where batches of small arms are involved. Sequential serial numbers means that only the first and last weapons in the series need to be traced. Battlefield sweepings involving a mix and match of assorted weapons can be more time consuming. There are some that may not be traceable simply because records no longer exist after 10 years. This is certainly the case for much of the World War II vintage material that is still in circulation. In any event, it must be remembered that tracing does not always lead back to the trafficker; in most cases it just identifies the point of diversion or the non-existent end-user. Once the weapons trail ends, then other investigative techniques take over to trace and track the people concerned.

3.1.10 Recommendations

Marking Methodology

1. The unique identifier must be marked on the frame or receiver of the firearm.

2. All markings must be made permanent by engraving, casting, or stamping in a manner not susceptible to being readily obliterated, altered, or removed.
3. Borrowing from US best practice, (effective January 30, 2002) all markings are required to be a minimum height of 1/16 inch (0.2cm) and a depth of at least .003 inches (0.05cm) for all required markings placed by importers and manufacturers.
4. Manufacturers are required to mark all weapons prior to removal from their premises.
5. Importers are required to mark imported weapons and notify the national record-keeping agency within 15 days of the date of release from Customs.

Marking Content

Mindful of negotiated agreements, such as the UN Firearms Protocol, the OSCE Document on Small Arms and Light Weapons and the OAS Agreement, the following recommendations respect the national language, alphabet and numbering systems in use worldwide and take into account that it has not been possible to agree upon one universal standard. Nevertheless, in the absence of a set standard, work should continue to create a minimum standard for all SALW, which ensures that,

1. Upon inspection, the complete unique identifier is immediately apparent and readily identifiable and;
2. Each weapon is individually marked to identify
 - the country of manufacture,
 - year of manufacture and
 - its unique identifier.

Import Marking

1. Import marking must become mandatory and used as a means of verifying arrival in the country of permanent import.
 - (a) Where firearms are produced for a specific export market and the importer's details are marked at time of manufacture, the importing country should apply an additional stamp to verify delivery and entry into the national records, thereby, validating the importer's mark.

- (b) Otherwise, import markings should not be applied until after the weapons have been declared to the relevant authority at time of import and before delivery to the military or the commercial arms dealer.
2. Import marks need not be more complicated or costly than a CIP Proof Mark indicating a country code and year of import stamped on each weapon.
3. Where the original manufacturer's marks on imported weapons are not user-friendly to the importing country (for the purposes of unique identification and/or record-keeping), the importing country should stamp such weapons with its own supplementary unique identifying markings and use these for its record-keeping (consideration should be given to the exporter bearing the cost in such cases).

Marking Essential Component Parts and Spare/Replacement Parts

Essential component parts should be marked to ensure they can be readily cross-referenced with the "mother weapon". Cooperation and coordination is needed between the world's arms manufacturers to agree on a marking system for replacement or spare parts. To avoid ambiguity or duplication, the system needs to be unique to each factory and allow identification of the manufacturer, **year of manufacture** and the **unique serial number**. (This may be more idealistic than realistic, but it is worthy of discussion).

Record-Keeping

Computerization must rapidly replace manual paper driven systems. Despite negotiated treaties and protocols (e.g. UN Firearms Protocol and OSCE Document), and mindful that weapons have a long shelf life, countries should be encouraged to maintain all records for an indefinite period. Electronic storage medium can easily accommodate this requirement, and facilitate rapid search and retrieval for tracing purposes. In the US, it is a statutory requirement that when commercial arms dealers go out of business, their records have to be handed over to the Bureau of Alcohol Tobacco and Firearms (ATF). This common sense approach should be replicated in every country. Interoperability between national systems is also a critical area. The RCMP, for example, are working with a computer software company to develop a programme which enables different systems to "talk" to each other in the same computer language with one

shared encryption standard. The minimum data standards require individual records for each weapon (with similar considerations for spare or replacement parts).

1. Manufacturers

- Make, Model/Type, Calibre;
- Date of manufacture;
- Unique identifier or serial number;
- Details to identify to whom sold or transferred.

2. Manufacturing Country

- Access to the manufacturer's records or a duplicate record; and
- Subsequent records detailing all transfers or transactions within the domestic market⁴ and the individuals concerned until either permanently exported or destroyed.

3. Importing Country

- Make, Model/Type, Calibre;
- Country of manufacture and/or export;
- Manufacturer's unique identifier, and/or;
- Replacement national unique identifier;
- Details of additional import markings;
- Date of import;
- Details to identify the importer;
- All subsequent transactions prior to destruction or permanent export.

4. Military Arsenals (national central agency)

- Make, Model/Type, Calibre;
- Unique identifier used for record-keeping;
- Date commissioned;
- Military unit to whom issued and date;
- Date returned for re-issue/disposal/destruction;
- Date decommissioned;
- Details to identify to whom sold or transferred.

A department within the national central agency should also take responsibility for maintaining records of all lost or stolen military small arms and light weapons, and consideration should be given to circulating these to an international database using the Interpol IWETS network.

5. Individual Military Units

Armourers for individual regiments and units should hold supplementary records:

- Individually listing all weapons supplied by the national central agency; and
- All weapons captured or otherwise acquired by regiments and taken into service (also notified to the national central agency);
- Details of any additional marks used for stock control cross-referenced with each weapon's recorded ordnance markings.

6. Commercial Arms Dealers (Surplus Ex-Military SALW)

- Make, Model/Type, Calibre;
- Country of manufacture and/or export;
- Markings used for record-keeping;
- Date of acquisition;
- Details to identify all parties involved, e.g. vendor, broker and shipper;
- Date and method of disposal;
- Details to identify all parties involved in the sale, e.g. purchaser, broker and shipper.

3.2 EXISTING NATIONAL, REGIONAL AND GLOBAL SYSTEMS

3.2.1 National Systems—Marking and Record-Keeping

Administration and enforcement controls for the manufacture, import, export, and registration or record-keeping of small arms varies greatly worldwide and it would be impractical in this paper to list individual measures for every country.

However, in general terms, with regard to small arms manufacture, every arms producing country has some form of regulation controlling the production and marking of its weapons. Some may be no more than self-regulation where marking is used for internal quality and stock control and access to the manufacturers' records is exploited by law enforcement agencies on a case-by-case basis. Other countries, such as CIP member States have statutory regulations requiring specific manufacturers' markings, including a unique identifier to guarantee quality and safety of the user.⁵

Domestic record-keeping varies between manual paper driven systems and advanced automated computer databases. In the Southern African context, for example, only Namibia and South Africa have automated record-keeping systems. Other countries in the region, such as Botswana, have a manual paper based system.

In the UK, the Ministry of Defence maintains a database for all domestically manufactured or imported military weapons for issue to the British Armed Forces. However, transfers of surplus military weapons between commercial arms dealers are not recorded on this database. The UK is not untypical amongst EU member States in that it does not yet have a national database of all firearms and ex-military small arms in private and commercial ownership. Instead, reliance is placed on legislation requiring firearm owners and commercial arms dealers to maintain for ten years individual records for each weapon in stock plus details of all transactions.

Automated national record-keeping systems speed up the tracing process and avoid the risk of tipping-off rogue arms dealers. The latter is a constant problem caused when police and customs officers have to visit a dealer's premises to physically inspect the register looking for specific transactions. The absence of a remote access national database, which records transactions in the private sector, greatly reduces the effectiveness of sensitive police enquiries to trace the sources of illicit weapons.

In Northern Ireland, the authorities have created a ballistics register for every police and civilian held firearm. At the time of registration or import, every weapon has to be submitted to the police for test firing. The fired bullet and cartridge case are then retained by the police for forensic comparison in the event that the weapon is used in crime or, in the case of police weapons, a lawful shooting. This novel approach has a number of benefits, including crime prevention, as firearm owners know their weapon can be readily traced if it is used in a criminal shooting.

3.2.2 Regional Systems—Information Exchange and Tracing

Southern African countries recently agreed the SADC Protocol on Firearms as the regional mechanism for exchanging information. However, only two States have so far ratified the Protocol. In practical terms there is very little exchange of information taking place because some countries find

it extremely difficult to retrieve information from their disparate record-keeping systems.

In Europe, the European Council agreed in 1991 to what is commonly termed the “Directive” (Directive 91/477EEC). This introduced a harmonized Community system to licence the movement of firearms and ammunition between EU member States. As a supporting measure, it required member States to set up the Weapons Information Exchange System (WIES) to share information about sales and transfers of firearms and ammunition between jurisdictions. EU law enforcement agencies also have access to the “Sirene” database,⁶ which records details of all stolen weapons in Europe.

In addition, each member State has a designated National Contact Point, which takes responsibility to notify its counterparts of all firearms transfers leaving its jurisdiction (exports) and, in turn, receives similar notifications regarding imports and firearms in transit through their jurisdiction. EU firearms imports and exports involving Third Countries (non-EU) are subject to the individual regulations of the particular member State, but these are not harmonized. Consequently, with the introduction, in 1993, of the free trade zone within a borderless Europe, the lack of consistency between member States creates loopholes for traffickers to exploit. It is also surprising to find in the 21st Century that WIES is entirely paper driven and reliant on the exchange of faxes, which are rarely translated into the language of the receiving State.

The European Commission is currently reviewing the Directive and intends to present (as yet unspecified) legislative proposals during 2002 to harmonize controls taking into account the requirements of the UN Firearms Protocol.

State-to-State and commercial transfers of military small arms and light weapons are generally excluded from the Directive. Instead, since its inception in 1996, EU countries have operated within the provisions of the Wassenaar Arrangement to exchange information about conventional arms exports. The Wassenaar Arrangement applies to a total of 33 countries worldwide. However, the transparency measures it introduced do not require member States to disclose specific details to identify individual weapons by their markings; only that the transfer took place.

Nevertheless, whilst the Wassenaar Arrangement does not provide the means to create a weapon specific database, if records could be computerized and expanded to include the **quantity, model, calibre and country of manufacture**, then these records could be referred to as a pointer for subsequent tracing enquiries where identical model weapons have been recovered.

Looking to the Americas, there are two important initiatives underway involving the Inter-American Drug Abuse Control Commission (CICAD), the UN Regional Centre for Peace, Disarmament and Development in Latin America and the Caribbean in Lima (UNLiREC) and the Organization of American States (OAS). The first follows the OAS General Assembly Resolution to counter the proliferation of and illicit trafficking in small arms and light weapons (5th June 2001 AG/RES.1797 [XXX1-0/01]). This involves the application of the “CICAD Model Laws and Regulations” to develop harmonized national legislation and regulations throughout the OAS region and Cuba to combat illicit trafficking in firearms (and ammunition, explosives and related materials). The RCMP have provided the same IT programmes it used to set up the Canadian Firearms Registry to drive an Internet-based system of registration and record-keeping called “SALSA” (Small Arms and Light Weapons Administration).⁷



The critical elements of correctly identifying weapons and their markings are fundamental to this system. Weapons dealers will be required to register with SALSA and, once authorized, will be able to record details of individual weapon transfers on-line via secure Internet channels. Alongside SALSA a parallel system will be maintained called “FASTRACS”. This will collate all the disclosures into one regional database listing individual details for each weapon disclosed to the SALSA system. Examination of that collective database will be restricted to law enforcement agencies using encrypted Internet access. The benefits of SALSA and its parallel “FASTRACS” system are that law enforcement agencies will be able to remotely access the regional database and trace or track the movement of specific weapons transferred via the network, and these searches can be run in a matter of minutes.

The second UNLiREC/CICAD/OAS initiative involves the development of the “Regional Clearing-house Project on Firearms, Ammunition and Explosives”⁸ and one of its objectives is the collection and destruction of surplus and illicitly trafficked small arms and light weapons.



An important element is to identify and evidentially record details of seized illegal weapon caches prior to destruction and use that information to trace the sources of illicit supply. To support this project, the RCMP is again making available its technology with the Firearms Reference Table. Training packages are currently being developed involving evidential procedures for identifying, cataloguing and tracing weapons, which will include the use of IWETS.

The US is a major arms producer and exporter and the ATF is pivotal to much of the worldwide tracing of firearms through the National Tracing Center (NTC). Access to NTC records can be made direct by law enforcement agencies or routed via their Interpol NCB. ATF records include all commercial sales and exports of civilian and surplus ex-military weapons. The ATF can also facilitate access to the US Department of Defense to check their records of US military issue weapons on a case-by-case basis.

3.2.3 Recommendations

1. Through international development outreach programmes, introduce harmonized regional controls based on the CICAD/UNLiREC/OAS initiatives.
2. Encourage countries to set up computerized national record-keeping systems; potentially one for civilian and commercial holdings and a second for military holdings.
3. Adopt the IWETS as the standard for international information exchange to trace illicitly trafficked weapons.
4. Encourage countries, which are signatories to treaties and protocols aimed at transparency over arms exports, to establish a member State-wide record-keeping system, which collates on to a computerized database all disclosures to individually identify the weapons involved. Politically sensitive transfers or transactions, if not specific to each

individual weapon, should as a minimum give sufficient information to benefit subsequent tracing, e.g. to include the **quantity, model, calibre and country of manufacture.**

3.2.4 Considerations

Transfers disclosed to record-keeping systems can be cross-referenced with the Interpol IWETS database of lost or stolen firearms to identify when illicit weapons reappear on the market and help identify potential traffickers.

The legal arms trade needs a system of mandatory disclosure to help prevent diversion. Mandatory disclosure will require statutory underpinning to provide the necessary legislation, which allows for proactive monitoring by the authorities. This could mirror existing legislation that requires advance disclosure of financial transactions to national authorities to counter money laundering. Transfer disclosures need to include sufficient information to identify all relevant parties involved in the transaction. Where a transfer subsequently leads to diversion and illicit trafficking, then the people involved should be “flagged” on the system. Any subsequent transaction involving one or more of the same parties can then be identified as potentially suspicious. The capacity to proactively monitor mandatory disclosures of intended transfers on the arms market, using computerized record-keeping systems looking for these common denominators engaged in illicit activity, enables the authorities to intervene early and either prevent, disrupt, or arrest and prosecute the traffickers. (“Front companies” are a regular feature of arms trafficking; set up for a one-off transaction by perpetrators who quickly move on. Nevertheless, intelligence can be collected to create profiles enabling the authorities, for example when validating import/export licensing applications, to identify common denominators or tell-tale hallmark precursor activity, which indicate a potential “front company” and an impending illicit transaction).

3.3. GAPS IN EXISTING CONTROLS OVER THE LEGAL ARMS TRADE

The most serious gaps can be summarised as follows:

- Limited verification of the validity of End-User Certificates;

-
- Limited proactive investigation to identify when a potential “front company” is being set up for a one-off transaction;
 - Absence of accompanying shipping documentation to individually identify the weapons transferred;
 - Lack of adequate prior notification to the import control authority listing each weapon individually by its markings;
 - Misrepresentation of consignments to avoid import duty and bypass costs of import marking and/or Proof testing with a knock-on effect to the accuracy of national records;
 - Lack of harmonized import/export control measures involving cross-referencing import and export transfer declarations to ensure weapons declared actually tally with those presented at import which, as a consequence, provides an opportunity for diversion;
 - Lack of harmonized delivery verification measures to ensure import control authorities individually inspect arms imports prior to delivery and ensure the details for each weapon are recorded on the national system;
 - Absence of harmonized controls over in-transit consignments to prevent change of end-user whilst en route in contravention of the original transfer authorization;
 - Lack of joined-up domestic government control whereby responsibility for “policing” the arms trade becomes fragmented between various departments and agencies, each with differing vested interests, and inter-departmental consultation is paper-driven rather than computerized;
 - Absence of national databases holding the central computer records: one for all military holdings and a second for all private/commercially held small arms and firearms;
 - Failure to integrate the national database for recording commercial transactions with the national police intelligence database. The latter is an essential element, as a means of verifying the status of individuals concerned to check for unauthorized or unlicensed people and businesses, checking for bogus “front companies” and identifying common denominators from previous transactions that led to illicit trafficking.

To evidence the consequences of these gaps, the following are examples of illicit shipments intercepted by police at Heathrow Airport during 2000 described amongst other things as:

- “Consolidation”—4 x 25mm “Bushmaster” chain-guns and 1 x 40mm grenade launcher; M16 self-loading and full auto rifles; plus revolvers;
- “Exhibition Goods”—semi-auto rifles, sub-machine gun and machine gun;
- “Scrap Arms”—minimum of 3 shipments from Vietnam of ex-US weapons including pistols, heavy machine guns, light machine guns and a mini gun;
- “Sporting goods”—assortment of sub-machine guns and other military weapons;
- “Tank Turret Parts”—7.65mm machine guns and 20mm chain guns;
- “Training Aids”—3 x RPG 7—rocket propelled grenade-launchers;
- “Trophy Arms”—several shipments comprising 490 x Thompson sub-machine guns; 3,286kgs (125) x MG34 and MG 42 light machine guns; 151 x Beretta M38 sub-machine guns; and 47 Steyr MP34 sub-machine guns.

In addition, despite protocols, such as the Wassenaar Arrangement, the conflict between transparency and protecting national security interests means many countries are still hesitant to disclose specific details about all transfers and transactions involving military small arms and light weapons.

Another area where gaps can occur arises from the growing partnership between the NGO Community and Government Agencies in the fight against arms trafficking. Protocols are needed to enable this partnership to flourish by making available the established law enforcement networks, such as Interpol and IWETS, in what is effectively an arms control context. To achieve this, NGOs and their law enforcement agency partners need to share a common mission with the same values and objectives.

3.4 BUILDING ON EXISTING PRACTICES

A fully implemented UN Firearms Protocol is pivotal to controlling the international arms trade and it is the cornerstone for all future activity to combat illicit trafficking in small arms. The Protocol builds on existing practices amongst UN member States and, for the first time, introduces not just politically-binding but also legally-binding minimum standards for regulating and controlling the legal arms trade to prevent illicit manufacture, diversion and illicit trafficking. Whilst the Protocol is primarily a regulatory law enforcement instrument for “policing” the commercial firearms trade,

its provisions have a direct read across for investigations into the illicit small arms market including, for example, Articles 7 (Record-keeping) and 8 (Marking). The Protocol is supplementary to the UN Transnational Organized Crime Convention, and Articles 18 (Mutual Legal Assistance), 26 (Measures to enhance cooperation with law enforcement authorities), 27 (Law enforcement cooperation) and 29 (Training and technical assistance) within the Convention provide the legal framework for multi-jurisdictional cooperation, including tracing enquiries.

However, the Protocol and its mother Convention have limitations when it comes to “policing” the small arms market. For example, the “scope” of the Protocol limits its provisions to those, which do not involve State-to-State transactions, or State transfers where national security interests may be compromised. Therefore, in examining how to build on existing practices, it is important to differentiate between State-owned arms manufacturing industries and those in the private sector (including commercial arms dealers). Second, it is important to differentiate between the types of transaction and transfer involved. In general, these can be categorized as State-to-State; State to non-State actors; commercial to State; commercial to non-State actors, and dealer-to-dealer. The next stage is to determine which aspects of the international arms trade can realistically be controlled through transparent measures, such as the UN Firearms Protocol, and those which are potentially outside due to national security interests.

In making this analysis, it is important to remember that whilst State-to-State transactions or State transfers may not be the source of illicit supply, they can be the start of a process that ultimately results in diversion and illicit trafficking. Therefore, it is vital that post-event access to a State’s records is made available to assist in tracing.

As a general rule, every transaction or transfer of military small arms licensed by the State or involving State-owned arms manufacturers should be open and transparent and, regardless of the States involved, mirror the transparency agreements contained in such politically-binding treaties as the OSCE Document and the Wassenaar Arrangement. However, realistically there may be limited occasions which fall outside and, for legitimate national security reasons, there will be little opportunity for law enforcement agencies to successfully trace the weapons involved.⁹

With the scope of the Protocol firmly in mind, it should nevertheless be possible to establish a marking, record-keeping and tracing mechanism that covers the vast majority of transfers and transactions. Consequently, existing practices can be expanded to embrace virtually every aspect of the market, as follows:

- There should be no bar on the international free circulation of information individually identifying all lost or stolen SALW. The correct vehicle is the Interpol IWETS database and it should be mandatory for every country to ensure the system is updated with relevant weapons.
- Similarly, following the UNLiREC/OAS/CICAD initiative, there should be no bar on the free circulation of information individually identifying every transfer or transaction on the commercial market involving surplus ex-military small arms and light weapons, including those sold as surplus stocks by State-owned arms industries. It should be mandatory for member States of economic regions to forward the information to a regional database, including all relevant manufacturers', import and other supplementary markings to individually identify each weapon and the records should be cross-referenced with the parties involved in the transfer or transaction.
- With regard to transfers and transactions involving State-owned or State controlled military stocks, at the very least the weapons should be uniquely identifiable and marked as having originated from one and then imported by another. Records in both countries (and any subsequent) should provide sufficient detail to enable subsequent case-by-case tracing enquiries to individually attribute a specific weapon to the party having last recorded legal possession, including the parties involved in acquiring decommissioned ex-military stocks. In the latter case, as with Switzerland,¹⁰ each weapon should be clearly marked to show it is no longer in a military arsenal.

Complementary examples of existing good practices can be found in treaties and protocols involving member States of the UN, OSCE, EAPC, NATO, OAS, EU and CIP amongst others.

3.5 LESSONS THAT CAN BE LEARNED FROM OTHER COMMERCIAL SECTORS

Developments in stock control and security systems have led to the design of a variety of microchips, which can be implanted into suitable parts of small arms and light weapons and scanned to reveal their unique identifier. These have the added benefit of supporting automated record-keeping systems.

Chipping military small arms and light weapons has tremendous benefits for the future in tracking the subsequent disposal and movement of surplus arms from Government stocks as well as recovering stolen weapons. The downside, however, is that once it becomes common knowledge, traffickers could quickly disable or remove the chip and authorities would once again be reliant on conventional markings. In addition, there are practical difficulties involving the availability of compatible scanners out in the field to identify recovered weapons.

Notwithstanding this last point, there may be specific occasions, involving a potentially suspicious transaction, when the relevant authorities may wish to exploit this technology and covertly deploy implanted microchips as a means of evidentially verifying the history of a consignment should it be recovered subsequently in the hands of an illicit end-user.

Another method of stock control is borrowed from supermarkets. Barcodes are commonly used in the UK for record-keeping purposes by police to catalogue seized firearms. Barcodes are applied on self-adhesive labels in places where they can be readily scanned but avoid damage through daily handling of the weapon. For validation purposes, the barcode is cross-referenced with the actual manufacturer's markings listed in the departmental records. Whilst this will not defeat sanitization, it provides an inexpensive means of quick identification where the issue and return can be simplified through an automatic link to computer records to update stock control. There is potential for additional labels to be concealed inside the grips or furniture of military small arms to aid subsequent tracing. The Swiss arms manufacturer, SIG, already incorporates laser etched barcodes on various parts as an additional security measure that can be exploited for identification and tracing.

The South African authorities assessed a variety of alternative methods of marking, including the “smart handgrip” (which only allows the weapon to be fired once it has verified the user’s identity) but found them to be prohibitively expensive, which is why conventional stamping is still preferred. In addition they reviewed existing systems for controlling dangerous drugs and nuclear and biological agents to see if they could be exploited in an arms control context, but they found them to be disproportionately bureaucratic for their purposes.

The most cost-effective means of building-in security features is at the time of manufacture. However, as these will be of greater benefit to law enforcement agencies than the manufacturers, without statutory underpinning, the introduction of such measures relies entirely on the goodwill of the Industry.

One area, which can be borrowed from another aspect of policing, is direct computer access to commercial databases. Such systems are available in the UK, for example, for accessing communications data direct from the databases operated by the telephone networks. In the US, a computer programme, called “Access 2000”, allows the Bureau of Alcohol Tobacco and Firearms (ATF) similar 24-7 on-line access to records held by certain domestic arms manufacturers and importers. This innovative approach leads the way for future partnerships between the arms trade and law enforcement agencies to rapidly access data for tracing purposes.

Direct comparisons can be made between the global automotive industry and the arms trade. The following illustrates the advances made in the automotive industry worldwide to protect against theft and trafficking. All of these can and should be replicated across the arms trade without exception.

- **(Unique identifier)** For quality control and security, vehicles are marked before they leave the production line with a unique 17 character alphanumeric coded, the Vehicle Identification Number (VIN). The VIN is clearly marked in one accessible location and a second duplicate mark is stamped in a semi-covert place elsewhere on the chassis. Coordination and cooperation throughout the worldwide industry means that the alphanumeric codes used for VINs remain unique, not just to the manufacturer but also to their individual

factories. The VIN codes are also supplied to police worldwide to assist with vehicle identification. The following VIN illustrates the point:

W A U Z Z Z 8 L Z X A 1 1 7 1 1 5

W A U = Manufacturer, country and individual factory code
Z Z Z = is a filler for those manufacturers which do not have a relevance for all 17 characters.
8 L Z = identifies the model and whether for the domestic or export market.
X A = identifies the month and year of manufacture
1 1 7 1 1 4 = the individual serial number
 (For weapons production, random numbers can replace sequential serial numbers to overcome concerns in countries, like China, that the latter can identify the year-on-year total output for each of their State-owned factories).

- **(Essential component parts)** Ford Motor Company, for example, uses the last seven digits of the VIN (the serial number element) to create the engine number. All major components are branded to prevent counterfeiting and given product codes which change yearly.
- **(Record-keeping—Manufacturers)** Manufacturers maintain records of each VIN issued cross-referenced with the vehicle details and point of sale.
- **(Record-keeping—Nationally)** Vehicles are registered on national computer databases, which record descriptive details, including the VIN, cross-referenced with those of the owner. Records held by the authorities track each vehicle's life from birth to death (or permanent export).
- **(Import declaration and record-keeping)** Imported vehicles must be declared on import and require registration as above.
- **(Import marking)** Imported vehicles require identification plates using characters compatible with the national system.
- **(Diversion prevention)** Vehicles considered to be at greatest risk of theft can have additional security measures, such as tracking devices fitted to aid recovery.

- **(Tracing)** Details of all stolen vehicles are recorded on national and regional databases, and with Interpol for worldwide circulation.

Whilst these measures do not necessarily deter car thieves, they provide effective means of identifying stolen vehicles and ensuring their ultimate return to their lawful owners. This is an important consideration for firearm owners who similarly want the reassurance that if their guns are stolen and recovered by police, they can be identified and returned.

With regard to ammunition, a recent innovation in crime prevention and detection, called “SmartWater”¹¹ can be utilized with ammunition to uniquely mark batches to assist with subsequent tracing. “SmartWater” is a non-corrosive chemical solution, which is prepared in individual batches that can be sprayed on to any product to assist in tracing its origin. Each batch is made to a unique formula. The solution dries quickly to leave a permanent coating, which is only detectable under ultraviolet light. The chemical signature for each batch of “SmartWater” used can be cross-referenced with the ammunition manufacturer’s records; e.g. the labelling on external packaging and the head-stamp marks of individual rounds within each box, to provide sufficient detail to track distribution. Subsequent forensic examination and analysis of recovered ammunition sprayed with “SmartWater” will identify the precise batch of solution used from which to begin the tracing process. “SmartWater” could be very effective as an import marker for countries wishing to identify imported ammunition. External packaging could be removed to enable every round to be sprayed before being re-packed and sent on.

An alternative to “SmartWater” is the “Mighty Dot”.¹² Created on a chemically treated polyester substrate, each dot is around 1mm in diameter and contains a laser etched code number, such as a vehicle’s VIN or a weapon’s unique identifier, or a national import code for batches of imported ammunition. Dots can be supplied either “dry” or more usually suspended in a custom made adhesive designed to fluoresce under ultra violet light. Mighty Dots can be applied in a brush-on form or in a spray. Once applied the sheer volume of dots makes identification straightforward using a simple hand held microscope while removal is so complicated and time consuming that it is impractical.

3.6 STORAGE AND ACCESS TO THE INFORMATION

3.6.1 Storage

To accommodate the understandable sensitivities of governments, records for military stocks should be kept separate from commercial and civilian record-keeping systems. It is unlikely that an international database, which records the details of each individual weapon transferred, is a viable prospect. There will be some tensions between the proposals for a transparent CICAD/UNLiREC/OAS SALSA system and individual national security interests of the countries involved. Where this occurs, it is imperative that an independent national record is maintained which can be made available on a case-by-case basis for specific tracing requests. SALSA will be maintained by UNLiREC on behalf of the OAS countries. This will contribute to its overall integrity and provides a helpful benchmark for any other regional database being considered, as it would seem prudent that the data-holder should be an independent trusted third party.

Commercial and civilian databases should be operated by an agency¹³ with a statutory inspection and enforcement function, such as police or customs. Military databases should be controlled by one national defence agency on behalf of all the armed services. This practice is already in place in countries like South Africa where the South African National Defense Force maintains the automated military register, and the South African Police Service operates the commercial and civilian database.

Records of all lost or stolen firearms and military weapons should be circulated worldwide by being posted on the Interpol IWETS database, as well as on any regional system, such as the European Sirene database.

There are understandable political sensitivities involving national security issues that influence the degree of transparency to which countries will allow access to their national records. This was emphasized by China during their negotiations on the UN Firearms Protocol. China declined to accept a proposal for a universal standard marking system involving a simple alphanumeric code. Instead, China encouraged UN member States to accept that all Chinese manufactured weapons will be uniquely and individually marked but the only element that could be readily understood by others would be the country of manufacture. China was unwilling to reveal its marking system and unlock the code for other countries to begin

tracing Chinese weapons. Consequently, all tracing enquiries would have to be referred to the Chinese authorities first and they would in turn, on a case-by-case basis, advise what marks were relevant and the country to which the weapon was exported. In addition, China declined to allow a speculative search of their records (a “fishing expedition”). Instead access would have to be made via the relevant Chinese authorities for a specific investigation that met the criteria for mutual legal assistance, as defined in the UN Transnational Organized Crime Convention. Potentially, this stance is typical of many countries, which makes it unlikely, despite transparency agreements, that specific details about every arms transfer will be disclosed to an international database.

Notwithstanding China’s position not to reveal its marking codes, there is a wealth of historic information on weapon markings held by intelligence agencies worldwide, which can be exploited for tracing purposes without necessarily having to refer back to the country of manufacture.

It is important to remember that there are many privately owned commercial arms dealers worldwide which hold large stocks of surplus ex-military small arms and light weapons. These stocks are traded on the global market, either between arms dealers or to State and non-State actors. Commercial arms dealers need to be subject to statutory oversight to ensure that accurate records are maintained detailing acquisitions and sales and all the parties engaged in each transaction. Records should be maintained to the same standard as military arsenals with each weapon individually listed according to its markings plus similar lists of all essential component parts and spares held. Stocks should be open for police and/or customs inspection and records should be automated and linked to the national record-keeping database.

3.6.2 Access

In view of the apparent sensitivities, access to any database, military or civilian, national or regional is restricted to law enforcement and intelligence agencies on a case-by-case basis for the purposes of prosecuting or disrupting organized illicit arms traffickers. Illicit trafficking is a criminal offence and gaining legitimate access to intelligence or evidence material to a criminal investigation is subject to rules within a judicial process and usually restricted to national police, customs, military and intelligence

agencies. Access to systems, such as IWETS, is limited to police agencies accredited with Interpol who meet specific law enforcement or criminal justice criteria. Similarly, access to the FASTRACS system behind SALSA will be via encrypted Internet channels and restricted to authorized agencies, which will be issued with individual User Names and Passwords.

It is questionable, therefore, whether access to such systems would be provided direct to NGOs. In the first instance, the application may have to come from the local police agency with which the NGOs are working in partnership. In addition, many countries have legislation prohibiting access to personal data unless to specific law enforcement or criminal justice agencies.

3.7 STORAGE MEDIUMS

Computerization is essential. Manually trawling through paper records involves a disproportionate cost in man-hours to the point where it has become prohibitively expensive for law enforcement agencies to undertake. It is essential that data storage systems are designed with rapid search and retrieval features to facilitate subsequent tracing requests. It must be remembered that tracing weapons on behalf of law enforcement agencies is not the core business of arms manufacturers and, therefore, introducing automated systems that reduce the burden on their staff responding to tracing requests must be seen as an advantage.

Good practice involves storage of imagery together with descriptive detail. One sample photograph can be used for each batch of identical make and model weapons together with a list of the individual markings for each weapon recorded in that batch. Imagery should be shared with law enforcement agencies to ensure that reference systems are kept up to date. For example, the RCMP FRT should be updated with all new designs and model changes for civilian and military weapons to maintain the integrity of the system.

3.8 MODALITIES FOR COMMUNICATING INFORMATION AND OPERATING A TRACING MECHANISM

Interpol utilizes two systems for communicating information: Orange Notices and IWETS. Orange Notices are the traditional method of

circulating information by fax and email to all NCBs (see below¹⁴). These are used where a particular methodology has been identified involving an illicit manufacturer or trafficker and NCBs are requested to check whether identical weapons from the identified source have been recovered within their jurisdiction.

Interpol Orange Notice—Operation Abonar (UK 1997-99)—used to trace a particular model of the MAC10 submachine gun illicitly manufactured in the UK in the late 1990's and trafficked throughout Europe. The weapon incorporated a unique design for the breech bolt, which provided the hallmark signature on which to focus the search. Using the Orange Notice, police in Ireland, Netherlands and Cyprus were able to link recovered weapons to the British police investigation.



IWETS is accessible to all NCBs, to exchange digital imagery together with descriptive text to facilitate tracing requests for recovered firearms. The RCMP, ATF and the Netherlands National Police Agency are currently developing an upgrade to the system. Law enforcement officers submit a tracing request to their NCB where staff transcribe the information sought on to IWETS (as shown below¹⁵) and then choose to which countries the request should be sent to for their individual record-keeping systems to be searched.



3.9 TRACING MODALITIES

National intelligence agencies have established communication networks for exchanging information with counterparts in the intelligence community to trace small arms and light weapons. Where the ultimate objective is to prosecute, intelligence channels can be used covertly first to identify the point where law enforcement agencies should subsequently begin an investigation. This approach protects the source of the information previously exploited by the intelligence service. Where disruption is the only realistic outcome, then matters will remain almost exclusively with the intelligence and security agencies and may result in political intervention rather than prosecution.

As such, there tends to be a two-tier approach to gaining access to national records. For example in the UK, police route their tracing requests through the National Firearms Tracing Service (NFTS) within the Interpol National Central Bureau (NCB) at the National Criminal Intelligence Service (NCIS). Depending on the nature of the investigation, the enquiry will then be forwarded to the equivalent NCB in the country of manufacture or last known point of transfer to make potentially overt enquiries. Alternatively, the NFTS can send a parallel enquiry to the Security Service (MI5) in London for a more confidential approach. Tracing military weapons will be handled internally by the Ministry of Defence. Cross-border enquiries about military weapons believed to have been illicitly trafficked may also involve the Security Service. Where practicable, subsequent prosecutions will be handled by either police or customs.

Tracing requests are normally completed on paper by individual officers in the field and then sent by fax to their NCB. Alternatively, copies of the IWETS proforma can be made available at local sites with access to the FRT, and then be sent by internal E-mail to their NCB. (For these purposes, the FRT can be made available via a secure Website, so that all officials can gain access to it via local Internet channels and search the Tables to validate their tracing request). Where necessary, the NCB will transcribe the information on to the electronic IWETS proforma and then forward it on to Interpol Headquarters in Lyon, France. There is also scope to add high-resolution digital photographs. Interpol HQ will then forward the tracing request to whichever countries are specified by the requesting NCB. They will also retain the information for analytical purposes looking to link recoveries to others notified centrally via the IWETS system. Depending on whether systems in the search countries are manual or computerized, enquiries will be checked, either on the automated national record-keeping system, or forwarded to the local police to inspect the records of the next person identified in the chain of ownership. Once a potential illicit source has been identified, no further executive action will be taken in the suspect's home country until the procedures for judicial cooperation and mutual legal assistance have been complied with. However, where offences in the home country are evident, then a local arrest and prosecution may take precedence. Depending on the seriousness of the case, the suspect can be extradited to face trial in other countries.

3.10 INITIATING TRACING REQUESTS

As previously outlined, there are two principle reasons for tracing:

1. To identify and prosecute those involved in arms trafficking, and/or
2. To disrupt the supply of illicit weapons.

(There is an additional reason for tracing, which is to gain intelligence about specific aspects of the "black" and "grey" arms markets:¹⁶ the individuals and States involved in illicit trafficking; the routes taken, communications and methodology, including finance and money laundering).

However, prior to reaching a stage where tracing can begin, there are some fundamental questions to be answered before law enforcement agencies can cross the threshold for multi-jurisdictional mutual legal assistance. The most critical is providing grounds for a reasonable suspicion

that a weapon is the proceeds of an illicit transfer. The principle should be that if there is no valid entry in the national record-keeping system to account for a weapon being in the country in which it is recovered, then it must be illicit.

However, where the integrity of national records is questionable, establishing whether a weapon is in fact illicit is not a straightforward procedure and detailed tracing is required just to establish its provenance in the country. Unless more recent import marks can shorten the enquiry, then tracing may have to start right back at the manufacturer. Lessons in tracing have been learned by the South African Police Service (SAPS) during their Firearm Tracing Pilot Project. The SAPS identified that the methodology required in tracing involves a series of steps, and the first two are critical: identification and status (legal or illicit), as shown here:¹⁷

Steps (i) to (vii):

- (i) Correct **Identification** of the weapon;
- (ii) Establish the **Status of the Firearm**—ownership and responsibility for control;
- (iii) Determine the **Origin of a Firearm** through tracing manufacturer and previous ownership (life history or provenance);
- (iv) Identify point of **Diversions** or **Loss** from licit market, which also needs to be investigated;
- (v) Determine the **Chain of Possession** since diversion or loss;
- (vi) Determine the possible **Criminal Use** before and after diversion or loss;
- (vii) Reassess the **Evidential Value** of the weapon as an exhibit in a criminal investigation.

It is important to view the two principle reasons for tracing (prosecution and/or disruption) as separate activities. The first sets out with the objective of dismantling the trafficking network and prosecuting those concerned; the second follows where the former is not achievable or unlikely to succeed and a compromise measure is needed.

It has proved more cost effective for countries, like the UK and US, to develop techniques borrowed from disrupting drug trafficking networks, which focus on upstream intervention rather than wait for contraband to reach its intended destination and then arrest. The objective being to

encourage countries along the trafficking routes to strengthen border controls and intervene at a much earlier stage along the illicit supply route.

To be achievable in an arms control context, it is important to have measures in place which allow transactions to be monitored whilst in progress. An important facet of any national record-keeping and tracing system must be the ability to proactively identify potentially suspicious transactions. In just the same way as money-laundering legislation has provided authorities worldwide with opportunities to proactively monitor money transactions, all weapon transfers must be the subject of similar mandatory disclosure legislation. However, the nature of the arms market requires prior rather than subsequent notification to allow the monitoring and tracking system to work and early intervention to be realistic.

3.11 APPROPRIATE RESPONSE TIMES

Responses to requests made to manufacturers and the authorities holding national records should be measured in hours rather than days. One month is considered the absolute maximum time it should take for the complete history of any weapon to be processed. Amongst many other considerations, which include the protection of human life, the judicial processes in most countries involve time limits, not only for periods of detention before charge, but also within which the Prosecution case must be arraigned before a Court. It is imperative, therefore, that requests to trace weapons, which are material to a prosecution, are fast tracked to minimize the risk of cases being abandoned through lack of corroborative evidence.

3.12. ESTABLISHING AND OPERATING COOPERATIVE MECHANISMS

The models for cooperative mechanisms can be found in the negotiated protocols and treaties of the UN, CICAD, OAS, OSCE and SADC amongst others where the objective is to increase regional and global security by reducing the proliferation of military small arms and light weapons and to disrupt illicit trafficking. The only limitation is the degree of transparency which will be acceptable as a minimum standard to enable information sharing to be of any real benefit.

The various regions of the world have very different needs when it comes to transparency and protecting national and regional security interests. Intra-EU weapon transfers, for example, are likely to be fully transparent whereas individual EU transfers to third countries may not. It would be unrealistic to expect countries to agree to one universal, global transactions database listing all transfers and transactions of military small arms and light weapons involving States (as either the buyer or vendor) that goes beyond the current disclosure system within the UN Register on Conventional Arms. However, countries may be more prepared to disclose greater detail to a regional database that meets the individual needs for promoting security and stability in that region, for example the SADC Protocol.

However, as previously mentioned in this paper, information concerning transfers or transactions, which subsequently lead to diversion and illicit trafficking, should be disseminated to the relevant police, customs, military and intelligence authorities worldwide, potentially via Interpol, to enable recovery of the weapons should they subsequently appear in another transfer or national record-keeping system. Such weapons are effectively "the proceeds of crime" or "stolen goods" and can be circulated via an Interpol Orange Notice or included on IWETS. Similarly, details of the people, businesses, and end-users concerned in transactions that lead to trafficking, should be shared amongst the authorities to look out for their involvement in any subsequent transfer as a signal indicating another potentially suspicious transaction.

3.13 CONFIDENTIALITY WHEN TRACING MILITARY SMALL ARMS

Depending on the number of jurisdictions involved and the cultural and political disposition of each, tracing enquiries may be routed first through confidential intelligence channels to find the evidence, and a point where overt investigative activity can begin, before a police or customs authority becomes involved. There are a small number of countries which would prefer not to reveal that they have cooperated in a tracing enquiry and law enforcement, intelligence and security agencies have well established procedures for protecting such sources. In these cases, police or customs will be directed to begin their investigations at a particular point that is sufficiently removed from the original source to protect them, but still

close enough to provide adequate forensic continuity to prove a connection between the traffickers and the illicit weapons.

Protecting intelligence sources and intelligence gathering techniques are critical issues when determining operational objectives for any investigation into illicit arms trafficking. Where long-term protection cannot be guaranteed, then alternatives to prosecution may need to be developed and practical measures, along the lines of upstream disruption, have to be explored.

Clear lines have to be drawn from the outset in any investigation to trace weapons as to whether the objective is to proceed to trial in a criminal Court or provide evidence to satisfy a Commission of Inquiry. Thereafter, decisions will need to address the long-term protection of witnesses and intelligence assets (sources), which will involve whether material is collected for “intelligence purposes only” or as evidence. Courts require a higher standard of proof, often referred to as “beyond reasonable doubt”, where witnesses present their evidence in person. However, an Inquiry can often accept evidence on “balance of probability”, which means that investigators can give evidence on behalf of intelligence sources without revealing their identity. This was demonstrated in the recent UN International Commission of Inquiry into arms trafficking in Rwanda.

Where the objective is to prosecute, then Article 24 of the UN Transnational Organized Crime Convention (UN TOC) makes it clear that State parties must set in place “appropriate measures to provide effective protection from potential retaliation or intimidation for witnesses in criminal proceedings”. Investigations may not be able to move forwards unless such guarantees of protection and confidentiality are given. In criminal cases, countries, such as the UK, can also invoke a procedure known as Public Interest Immunity to protect covert intelligence gathering techniques and prevent the identify of protected witnesses from being revealed in Court. In addition there are witness protection schemes that provide for the long-term security and safety of witnesses, and a number of countries have bilateral agreements to relocate protected witnesses.

To underpin such arrangements, Article 18(5) of the UN TOC (Mutual Legal Assistance) includes a provision requiring countries to comply with a request to maintain confidentiality. Furthermore, Article 4 of Interpol’s Rules on International Cooperation makes it clear that “the General

Secretariat shall take all necessary precautions to protect the safety and secrecy of police information and to prevent such information from being illicitly or improperly processed or communicated” and “staff shall be bound by rules of professional secrecy”.

3.14 LEGAL IMPLICATIONS OF UTILISING POLICE AND MILITARY TRACING MECHANISMS IN AN ARMS CONTROL CONTEXT

In discussions whilst researching this paper, some argued that law enforcement agencies should not become engaged in investigations to trace firearms or military small arms and light weapons unless the weapons are **illicit**. However, the proliferation of arms poses the gravest threat in developing countries where there is almost a complete absence of appropriate records. Consequently, tracing has to be undertaken as a matter of course whenever a batch of weapons is recovered just to determine whether they are potentially licit or illicit. As previously outlined in this paper one interpretation of “illicit” is that there is no record authorizing a weapon to be in the country where it is found. Another indication of what is meant by “illicit” can be found in Article 3(e)¹⁸ of the UN Firearms Protocol. In recognition that this is very much a condition of “which came first: the chicken or the egg?” investigations to trace weapons must be able to proceed on the basis that there are grounds to suspect that they are illicit rather than denying access to tracing mechanisms until the “illicit factor” has been proven.

“Tracing” is defined in Article 3(f) of the UN Firearms Protocol¹⁹ and is broad enough to entitle a competent authority in any State that is a party to the Protocol to initiate an investigation to trace weapons. However, this appears to exclude NGOs, as they are not a “competent authority” for the purposes of the Protocol. This leads on to three important questions:

1. Can access to existing law enforcement mechanisms and agreements on judicial cooperation be extended to entitle NGOs to utilize them for their own investigations?
2. Can these tracing mechanisms be utilized to investigate the destabilising proliferation of weapons in regions of conflict or post conflict where the margin between licit and illicit is blurred? and,

3. If Interpol is not up to the task and no is the answer to both of the above, then should an alternative tracing mechanism be created, which is accessible to NGOs, and recognized and given authority to operate alongside existing law enforcement mechanisms?

Answers to the above can be found amongst the Provisions of the UN Firearms Protocol (UN FP) and the UN TOC together with the Interpol Rules on International Police Co-operation (Interpol Rules). The first two documents are clearly aimed at increasing cooperation between police and customs as national “competent authorities”. They do not extend to NGOs. For the purposes of the UN TOC, cooperation is focused on the investigation of serious crimes involving an organized criminal group.²⁰ There is no doubt that illicit trafficking satisfies both of these requirements. Article 1 of the UN FP makes it clear that the purpose of the Protocol is to “prevent, combat and eradicate the illicit trafficking in firearms” and Article 12(4) says “States Parties shall co-operate in the tracing of firearms, their parts and components and ammunition that **may** have been illicitly trafficked”. Therefore, tracing can be undertaken just to establish whether or not the weapons are illicit. The “illicit factor” does not have to be proven beforehand. For NGOs to be able to exploit the UN FP, they will need to identify a competent authority in the country in which they are operating (police, military or interim UN Peacekeepers) to act on their behalf or work alongside them. Article 6²¹ of the Interpol Rules entitles any organization to ask Interpol for assistance to “process police information”. Whilst “police information” is not defined, tracing firearms is an everyday feature of Interpol’s work. Therefore, NGOs can ask for help from Interpol to trace military small arms and light weapons in circumstances that lead to a suspicion that they were illicitly trafficked. Provided either the local Interpol National Contact Bureau or one selected by the Interpol General Secretariat sponsors the NGO, then the investigation can proceed. The Interpol General Secretariat has positively supported previous joint NGO/competent authority investigations, including the UN Commission of Inquiry on arms trafficking in Rwanda. There is no need, therefore, to create an alternative tracing mechanism bespoke to the needs of the NGO community.

To further this argument, policing is also about “building safer communities”²² and reducing the fear of crime through preventive measures. It’s not just about enforcement of legislation and criminal investigations. Therefore, where the proliferation of arms is destabilising

communities, jeopardizing their safety and security, it is entirely appropriate that countries should be able to ask for and receive help from the international police community and utilize systems, such as IWETS, for much broader policing purposes.

It is important to remember that tracing investigations can often discover material which may ultimately need to be presented as evidence in Court to prosecute the illicit traffickers identified. Therefore, from the outset, those involved in such enquiries need to comply with the rules of evidence, disclosure, forensic continuity, and confidentiality, including the protection of personal information. Training NGOs in these disciplines is essential to ensure that where an inquiry ultimately identifies illicit activity, the evidence collected throughout exists in a form that can be presented without any question of its forensic integrity being compromised. It makes good sense for NGOs to work alongside individuals from the international police community, which does not need to include local forces if there is a likelihood of local collusion in arms trafficking.

To illustrate these points, in 1994 the UN Security Council set up the International Commission of Inquiry to investigate the flow of arms into Rwanda. Countries involved in the Inquiry included the Democratic Republic of Congo, Rwanda, Burundi, Uganda, Kenya, Tanzania, South Africa, Zambia, Belgium, France, UK, and the Seychelles. A variety of sources were used in these countries ranging from police and Interpol, customs, intelligence, media reporters, defectors, refugees and a large number of private contacts. All sources were kept strictly confidential. The Inquiry Team used their own in-house methods, involving established intelligence procedures, to grade the reliability of their sources and the accuracy of the information supplied in order to undertake tracing enquiries in respect of the weapons recovered. Tracing was able to link the weapons to commercial dealers and countries that condoned the supply in breach of the arms embargoes. The Inquiry Team were able to present their own evidence to prove these offences “on balance of probability” without the need to produce witnesses and compromise the latter’s confidentiality.

Access to police and military held databases can be problematic, as they may require additional judicial and national security hoops to be gone through. Access will, therefore, be on a case-by-case basis as an integral part of a specific criminal (or suspected criminal) investigation. Where records are held on computer databases, preset levels of access are often built in,

which restrict the amount of information available to investigators and provide sufficient detail to complete the trace without identifying more sensitive information.

Where bureaucratic obstacles are created, it should be possible to fall back on an independent committee, potentially at Ministerial level, to arbitrate where access to national records, civilian or military, is initially denied. It is important to remember though, that access to national records for tracing purposes has to respect the sovereignty of the countries concerned.

3.15 CONCLUSION

Marking fulfils a number of important purposes beyond providing a unique identity; it is essential for security in the event of theft, quality assurance and creating accurate inventories. Marking has to overcome many forms of attack from illicit traffickers who seek to avoid being traced by obliterating or falsifying a weapon's identity. Marking and record-keeping are pivotal in combating illicit trafficking and the tracing procedure is wholly reliant on their integrity. Unique unambiguous marking sustains accurate record-keeping, which in turn facilitates tracing and forensic attribution to an evidential standard. Marking methodology has to be effective in the fight against illicit trafficking and involve a degree of sophistication which, when combined with computerized record-keeping to fast-track tracing and tracking, creates significant difficulties for traffickers who want to avoid weapons being traced back to them. However, all this has to be achieved in a manner that is not beyond realistic capabilities given the political and economical constraints in many developing countries. One of the outcomes of negotiations on the UN Firearms Protocol is the realisation that we are only as strong as the weakest country involved in combatting illicit arms trafficking. It is vital that the developing countries are given every assistance to upgrade their systems for marking and record-keeping through outreach programmes led by the developed nations.

Notes

- ¹ The author would like to thank Mujahid Alam, Brigadier, Pakistan Military—UN Commission of Inquiry on Rwanda; Péricles Gasparini Alves, Director of UN LiREC; J.A.J. (Mike) Buisson, Assistant Commissioner, Royal Canadian Mounted Police Firearms Act Program; Riccardo De-Caris, Director Legal Section Support Services, South African Police Service; Murray A Smith, Chief Scientist—Firearms, RCMP Central Forensic Laboratory, Ottawa; Gary L Thomas, Chief, Firearms Programs Division, US Bureau of Alcohol Tobacco and Firearms; Dr. Stefano Toscano, Federal Department of Foreign Affairs, Switzerland; Representatives of the Australian Ministry of Defence; Representatives of the Swiss Ministry of Defence; Representatives of the British Security Service, Foreign Office, Ministry of Defence, HM Customs and Excise, and the National Criminal Intelligence Service.
- ² CIP member States: Austria, Belgium, Czech Republic, Chile, Finland, France, Germany, Hungary, Italy, Spain, Russia, Slovakia, and the United Kingdom.
- ³ The RCMP has licensed sales of their FREDES and FRT programmes to a private company, Computer Aids Incorporated—Gilles_Verner@notes.compaid.com—and, for example, FRT will cost between US\$ 1,000 and 1,500 to buy the complete database on 2 CD ROMs compared to the CDN\$ 7 million it cost to create.
- ⁴ It is appreciated that, on constitutional grounds, the US does not permit personal firearm registration. Nevertheless, tracing remains effective due to a federal requirement that all sales be recorded, and these are then notified to the ATF and centrally held at their National Tracing Center (NTC). (Other countries, which have legislated for firearm ownership, require individual licensing and registration).
- ⁵ Article 4 CIP Regulations requires the Proof House to verify that marks have been applied in a clearly visible and durable manner on at least one highly stressed component of each firearm detailing manufacturer, serial number and calibre.
- ⁶ Sirene is the computer system shared by those European countries which are also parties to the Schengen Agreement to exchange information between their law enforcement agencies. Amongst the information held are details of stolen high value vehicles and all stolen firearms.
- ⁷ <http://salsa.oceanus.ca/>
- ⁸ www.cicad.oas.org and www.unlirec.org.

- ⁹ It was notable during negotiations on the UN Firearms Protocol that a limited number of countries wished to preserve the right to exempt certain transfers and transactions from the scope of the Protocol. As a consequence, some weapons manufactured or imported for a particular national security interest could, for example, have no identifying markings.
- ¹⁰ Swiss military weapons are stamped with the national flag and the initial “A” plus a quality control mark, “KW+”. Weapons subsequently decommissioned by the Swiss military are each stamped with the letter “P” signifying they have passed into private ownership.
- ¹¹ www.smartwater.com.
- ¹² www.datadot-uk.com.
- ¹³ Whilst record-keeping in many countries is undertaken by a regional or federal police department, it is acknowledged that this can be a politically sensitive issue amongst shooting rights and civil liberty groups. There are arguments for the agency to be an independent commercial organization, statutorily underpinned to provide enforcement powers, but regulated by the national arms trade association with judicial oversight and inspection undertaken by a government department. However, this can be impractical, as police and customs need unrestricted live access to the record-keeping database to allow for proactive intervention against potentially suspicious transactions.
- ¹⁴ Reproduced by kind permission of NCIS NFTS.
- ¹⁵ Reproduced by kind permission of the RCMP.
- ¹⁶ Black = illicit, and Grey = State sponsored.
- ¹⁷ Extract from the SAPS response to the Swiss-French Initiative on a Tracing Mechanism.
- ¹⁸ “Illicit trafficking: the import, export, acquisition, sale, delivery, movement or transfer of firearms, their parts and components and ammunition from or across the territory of one State Party to that of another State Party if any one of the State Parties concerned does not authorize it in accordance with the terms of the Protocol or if the firearms are not marked in accordance with Article 8 of this Protocol.”
- ¹⁹ “Tracing shall mean the systematic tracking of firearms and, where possible their parts and components and ammunition from manufacturer to purchaser for the purpose of assisting the competent authorities of States Parties in detecting, investigating and analyzing illicit manufacturing and illicit trafficking.”

- ²⁰ UN TOC Article 2(a) “Organized criminal group shall mean a structured group of three or more persons, existing for a period of time and acting in concert with the aim of committing one or more serious crimes or offences established in accordance with this Convention, [author’s note: includes illicit trafficking] in order to obtain, directly or indirectly, a financial or other benefit”.
- Article 2(b) “Serious crime shall mean conduct constituting an offence punishable by a maximum deprivation of liberty of at least four years or a more serious penalty”.
- ²¹ Interpol Rules Article 6(1) “The General Secretariat may process police information:
- (a) obtained from sources accessible to the public;
 - (b) sent to it:
 - (aa) by an official institution concerned with the enforcement of the criminal law in a state that is not a member of the Organisation [Interpol], either on that institution’s own initiative or in reply to an enquiry the Organisation has addressed to a diplomatic mission of that state at the request of a National Central Bureau (NCB);
 - (bb) by an intergovernmental organisation performing its official duties”.
- Article 6(3) “When the General Secretariat receives police information from private individuals or corporate bodies other than those mentioned in Article 6(1), it shall register such information and may communicate it, together with any relevant information in its possession, to the NCBs of any States concerned. Thereafter, those NCBs shall, if necessary, take all appropriate measures to ensure that the information in its possession is correct and up to date and processing and communication of that information shall be governed by the same rules as those that apply to police information communicated to the General Secretariat by those NCBs”.
- ²² Part of the UK Home Office policing slogan.

CHAPTER 4

STRUCTURES AND INSTITUTIONS NECESSARY TO SUPPORT THE EFFECTIVE OPERATION OF A FIREARMS TRACING MECHANISM

Gary L. Thomas

The Bureau of Alcohol, Tobacco and Firearms (ATF) is presenting this paper to assist States in developing the structures and institutions necessary to support the effective operation of a firearms tracing mechanism. Tracing is a powerful law enforcement weapon in fighting firearms-related violent crime and illegal trafficking.

When we speak of firearms tracing, we ordinarily refer to the systematic process of tracking a recovered crime gun's history from its source (the manufacturer or importer) through the chain of distribution (wholesaler/distributor) to the first retail buyer and, ultimately, to the last individual possessor of the firearm.¹ Of course, there are several mechanisms to accomplish this, many of which begin at an earlier stage in the lifespan of the firearm. For example, in some tracing mechanisms there is a record kept at every transfer of the firearm, expediting the tracing process to the last lawful possessor. In any event, the tracing of firearms is generally understood to begin with a recovered firearm, usually by law enforcement in the context of a crime, and end, if successful, with the firearm's last possessor.

The question often arises why a gun should be traced, especially if the perpetrator has been apprehended. The first reason is often because the individual arrested was not lawfully in possession of the firearm, and there is every incentive to find out how an unauthorized individual obtained it.

There are other reasons as well. When tracing is conducted comprehensively, analysis can determine major trends in the illegal trafficking of firearms. Tracing and trace data can provide additional information helpful to law enforcement such as other crime guns recovered nearby; the names and addresses of known criminal associates of the purchaser—who may be involved in the instant crime; or, if the firearms have been reported stolen, tracing can furnish additional leads. In short, tracing coupled with proper analysis can be the most effective means to identify potential illegal firearms traffickers or to pinpoint where and when crime guns have been diverted from lawful commerce.

An effective tracing mechanism can also capture information about sales of multiple firearms, stolen firearms, and firearms with sanitized or obliterated serial numbers. Moreover, once recovered crime guns are traced, the information pertaining to the firearms, locations and individuals can be analyzed to identify trends and patterns of illegal firearms trafficking. Reports can therefore be generated which provide information about illegal firearms activity in a particular region or neighborhood; identify differences in the patterns and preferences of adult, youth and juvenile illegal activity; expand access to firearms-related enforcement information; and allow the initiation of local and regional reporting on illegal trafficking and possession.

Thus, law enforcement agencies can focus their limited resources to have the greatest impact on the reduction of firearm violence by adults, youths or juveniles; identify potentially corrupt licensed dealers or the black and gray market in firearms; target sources of the preferred types of crime guns; identify sources of inter-State or international trafficking; and produce a balanced law enforcement strategy to reduce violent crime in communities. In short, the value of tracing all crime guns in reducing the criminal possession and misuse of firearms cannot be overstated.

The value of tracing can be appreciated by the following real-life example:

In July 1997, the body of a 16-year-old girl who had died of multiple gunshot wounds was found along a roadway in Arizona. The local sheriff's office was seeking new leads in this unsolved homicide. A detective learned that a possible witness in the case had been arrested on unrelated drug charges. Upon examining the property found on the subject, the detective uncovered what appeared to be a sales receipt,

and he believed that the numbers might represent a firearm serial number.

The detective contacted ATF to trace the number. ATF was able to determine that the same serial number had been previously traced in connection with a drug crime. Further investigation revealed that the firearm used in the drug crime was still in police custody. Ballistics tests confirmed that the firearm used in the drug crime was also used to kill the 16-year old girl.

The detective interviewed the drug suspect, who admitted lending the firearm to two people on the night of the murder. These individuals were identified and arrested in connection with the murder. They both pled guilty and were convicted of second-degree murder.

The arrest of the two murderers would not have been possible had the officer not traced the murder weapon when arresting the subject on unrelated drug charges.

As evidenced by this example, it becomes clear how essential an effective firearms tracing system is in the fight against violent crime and illicit firearms trafficking. This paper will attempt to outline the basic structures and institutions necessary to support an effective tracing system (Section I), identify the existing structures and organizations that can assist in support of a tracing mechanism (Section II), identify the roles of the various players in an effective tracing system (Section III), evaluate the cost and effectiveness of three tracing mechanisms (section IV), and conclude with an overview of the impediments to an effective tracing system.²

The following discussion provides the means by which a State may establish a firearms tracing process.

4.1 FUNDAMENTAL STRUCTURES AND INSTITUTIONS

4.1.1 Legal Framework

Essential to any effective tracing system is a network of laws, regulations, and law enforcement structures with the capability of regulating the manufacturing, transferring and record-keeping of firearms.

Laws

Firearms are a durable commodity and pose an inherent danger if misused. Moreover, firearms are used as tools in most law enforcement agencies and the military and also serve the interests of hunters and other recreational sportspersons. Accordingly, any viable tracing system requires the enactment of a system of laws regarding the creation and distribution of firearms.

Consistent with a State's constitutional system, these laws should include specific regulations involving the following:

- Definition of a firearm:

Many national laws define a firearm by its functionality, i.e., whether it can expel a projectile, or by its lethality, i.e., whether the device can expel a projectile that can cause serious injury or death, while other laws define a firearm by its primary component part, e.g., the frame or receiver. It is important that the State provide a law that is sufficiently clear to ensure that those weapons to be regulated can be distinguished from toys, for example. In addition, a State may wish to include in its definition of firearms air guns, paintball devices, flare guns, starter pistols, or partially manufactured or deactivated firearms. In any event, the development of a workable definition is a necessary step for any tracing system.

- Marking of a firearm:

Because a tracing system relies primarily upon the marking or a combination of markings impressed upon a firearm, there must be laws that govern, in some degree, the procedures used for such markings. For example, a State may choose to issue blocks of numbers or codes for its firearms, or require the manufacturer or importer to perform the markings. The State may also consider requiring a standard size and depth for markings to discourage their obliteration.

- Record-keeping:

The marking of a firearm is of little value if the record of that marking is not retained, or is retained in a manner not accessible or subject to use by law enforcement. Accordingly, a State must issue laws that require, to some degree, the maintenance, retention and access of recorded marks upon a firearm and allow proper authority to access those records in a timely fashion to complete a firearms trace (e.g., 24 hours a day).

- **Licensing:**

Although not necessary to a tracing system, many States have established licensing systems to regulate the manufacture, marking and record-keeping of firearms. Such systems can serve as the means by which the laws are effected and provide an avenue for the necessary modifications of the laws due to changes in technology or State priorities or resources.

Regulations

Due to the variety of firearms and the size of the military and commercial firearms industries, no single set of laws can be comprehensive and flexible enough to respond to the needs of a tracing system. Accordingly, States need to establish regulations that can provide more specific guidance. For example, while a State might require marking of all statutorily defined firearms at the point of manufacture, it might not specify where on each firearm the markings must appear, or the size and depth of those markings.

Enforcement Authority

A legal framework necessary for any tracing system must not only include laws and regulations, but must provide an effective means for enforcing them. The enforcement authority can be accomplished through industry self-regulation accompanied by sufficient checks and balances, or by means of a police or regulatory body whose members ensure compliance by means of criminal or civil punishments for violators. Regardless of the method used to ensure compliance with the laws and regulations, an effective tracing system relies both upon clear rules and faithful compliance with those rules.

4.1.2 Industry Cooperation

Because many States have a robust commercial firearms industry, an effective tracing system must take into account the importance of industry cooperation. Several areas are critical: the proper marking of firearms at the point of manufacture or import, the value of record-keeping maintained for strictly commercial or proprietary reasons (such as repair), and the expertise often found only among industry members.

This last point should not be undervalued. Modern firearms have been manufactured for over 100 years. The number and variety of these firearms is tremendous, and a successful tracing system requires a fair degree of expertise in firearms identification. Some of the world's foremost experts work for or have worked for the major firearms manufacturers and have extensive knowledge important to a tracing mechanism. Accordingly, an effective tracing system must include in some fashion a liaison with the firearms industry as a whole.

4.1.3 Infrastructure

In addition to a legal framework and a liaison with the firearms industry, a necessary component of any effective tracing mechanism is sufficient infrastructure for collecting and disseminating information. At its core, a tracing system is a data collection and retrieval system. Information about firearms (for example, a serial number or a make and model) is collected, retained, and must be expeditiously retrieved. In this regard, a tracing mechanism must have an established means to accomplish this task. As discussed *infra*, this infrastructure may be rudimentary (a paper record of a firearms marking followed by a manual examination of this record), but it must be capable of providing the information in a reasonable period of time. Information that cannot be retrieved or can only be retrieved over a long period of time is of little utility. Indeed, the mark of failure of any tracing system is the inability to deliver accurate information in a timely fashion. This is why the advent of modern information technology (be it telephone, fax or computer) promises to be a boon to the establishment of an effective tracing system in many States.

States would also need to address whether to require a centralization of dealer records within a tracing facility or whether they would be granted access to a licensed dealer's records on a case-by-case basis.

4.2 EXISTING SUPPORTING STRUCTURES AND ORGANIZATIONS

Because firearms tracing is not a new concept or practice, there already exist several institutions and organizations that provide a supporting role in a tracing system. These involve both individual State institutions, as well as commercial, regional and international organizations.

4.2.1 State Tracing Centers

When a firearm is recovered at the scene of a crime, it must first be identified. If it can be determined where that firearm was manufactured, that State of manufacture can be contacted to provide information about that firearm. Because it is one of the leading firearms producing nations in the world, the US has developed a National Tracing Center (NTC) that accepts trace requests for US-source firearms from throughout the world.³ The NTC, under the jurisdiction of the Bureau of Alcohol, Tobacco and Firearms (ATF), is the only facility of its kind that is available 24 hours a day to receive trace requests for recovered US-source crime guns, which are US-manufactured firearms or foreign-manufactured firearms lawfully imported into the US and so marked. This tracing center maintains data on stolen firearms, firearms with obliterated serial numbers, firearms suspected to have been trafficked but not yet recovered in crime, multiple sales of firearms to the same individual, as well as over 300 million individual firearms transaction records from out-of-business dealers. ATF estimates that it now traces approximately 240,000 firearms annually. ATF's NTC, therefore, serves as but one example of an institution that can play an important role in any State's tracing system.⁴

4.2.2 Interpol

Interpol has over 170 offices throughout the world. It serves participating States by facilitating the exchange of information for circumstances in which a State-to-State trace request cannot be conducted.

Interpol facilitates this function through its Terrorism and Violent Crime Division, which issues a request to one State on the behalf of another State. In a tracing scenario, a State with a recovered foreign firearm can request that the firearm be traced by the State of manufacture. Using Interpol offers a standardized method for requesting the trace. Each State acts on the request received from Interpol, using the system accessible within its governmental environment.

In addition, Interpol also offers the Interpol Weapons and Explosives Tracking System (IWETS). IWETS is currently the only international analytical database designed to collate information on illegal firearms trafficking. IWETS offers support of a trace system through its function of tracking stolen and recovered weapons. In addition, it is anticipated that in

the future a firearm tracing query system would be added to this database, which will enhance Interpol's tracing capabilities.

4.2.3 Industry and Trade Groups

Some nations have established contacts with members of the firearms industry because the latter can provide assistance in the tracing of firearms. For example, ATF is electronically linked to several of the major firearms producers in the US, thereby permitting nearly instantaneous access on a 24-hour basis to important trace information from those producers. For example, once ATF receives a trace request involving one of these manufacturer's firearms, ATF can access their records electronically to identify when the firearm was produced and to whom it was transferred. Consideration should be given to instituting a similar program for States seeking to support a more effective and timely tracing mechanism.

4.2.4 The United Nations

The recent efforts of the UN to address the illicit manufacturing and trafficking in firearms and the misuse and proliferation of small arms and light weapons has provided impetus to those States seeking to establish a tracing mechanism to combat international firearms trafficking. The Protocol Against the Illicit Manufacturing of and Trafficking in Firearms, Their Parts and Components and Ammunition, supplementing the Convention Against Transnational Organized Crime, requires States to institute firearms marking and record-keeping systems for tracing purposes.⁵

In addition, the Programme of Action that was agreed upon following the July 2001 Conference on the Illicit Trade in Small Arms and Light Weapons in All its Aspects, provides additional encouragement and assistance to establish effective tracing systems for firearms.⁶

These efforts by the UN serve an important supporting role insofar as member States are encouraged to implement the structures necessary to support an effective tracing system. For example, both of the above instruments call for the establishment of a single point of contact that can be used to facilitate a firearms trace request from one member State to another. Such a single point of contact can be tremendously helpful in light

of the often myriad players (law enforcement officials, manufacturers, organizations, etc.) involved in conducting an international firearms trace.⁷

4.2.5 Regional Organizations

In addition to the UN, there exist several regional organizations that can serve the interests of a tracing mechanism. The Organization of American States (OAS), the Organization for the Security and Cooperation in Europe (OSCE), the G8 Nations (in particular, the Lyon/Roma Groups), the EU, the Inter-American Drug Abuse Control Commission (CICAD), and others, all provide a forum for the mutual exchange of information sharing that can facilitate a tracing mechanism. Naturally, each of these organizations may play a limited role in firearms tracing. The recent adoption of the CICAD Model Laws and Regulations has proven the vital role these regional organizations can play in the effort to combat illicit firearms trafficking.

4.2.6 Non-Governmental Organizations

Any effective tracing mechanism should not overlook the supporting role NGOs can play in fighting firearms trafficking. By focusing on the common agenda for curtailing firearms trafficking through an active tracing system, these organizations can work together with governments and industry members to ensure that firearms are marked and that records are maintained and accessible to law enforcement.

4.3 THE FIREARMS TRACING “PLAYERS” AND THEIR “ROLES”

4.3.1 Manufacturers, Wholesalers, Distributors, Importers, and Retailers

There are several critical players in any effective tracing mechanism. The first and most important role in tracing is played by the manufacturer of the firearm because it is the manufacturer who ordinarily places upon each firearm those markings that will enable the weapon to be traced. Moreover, many manufacturers maintain, either by law or for other commercial purposes, a record denoting the important information about the firearms (serial number, date made, etc.) and their disposition.

There are several important elements in the manufacturer's role that have significant tracing implications. These include:

- what markings to use (serial number, e.g.);
- where to mark (frame or receiver, barrel, e.g.);
- how to mark (engraving, roll stamping, laser etching, e.g.);
- height and depth of the marking;
- language, alphabet, character or symbols used in the marking;
- correction system for duplicate or erroneous markings;
- record-keeping system (computerized, retention schedule);
- compliance with laws of other States where firearms are destined for export.

In addition, it should be noted that the same issues are applicable where the manufacturer is State-controlled or where such manufacture is a function of the military. Moreover, where both systems coexist, there are additional considerations, especially where the markings requirements vary for military versus commercial manufacturer.

Clearly, any effective tracing system must have the full compliance of manufacturers in putting proper and lasting markings upon all firearms. Such markings should be user-friendly, legible, of sufficient height and depth to resist obliteration, nonduplicative, easily recordable and conspicuously located on a portion of the firearm. Subsequent transferees of the firearm will use these markings as a starting point for all future records, so it is imperative that they follow these minimum standards.

Another central player in an effective tracing system is the record keeper, who may be the same as the manufacturer. Considerations in this area include:

- what records are maintained (solely the serial number or other identifying information such as make, model, date of manufacture or transfer);
- how records are maintained (paper, computer database, backup systems);
- how long records are maintained (10 years, 20 years, indefinitely);⁸
- contingencies for collecting records when companies go out of business;

- accessibility of the records (physical location or accessible electronically);
- timeliness of retrieval system;
- retrievability of information (i.e., how the records are filed).

Wholesalers and distributors also play an important part in the tracing process because they form a link between the maker and seller of the firearm. More significantly, because wholesalers and distributors often deal in large shipments of firearms, they can be targets for theft or serve as the diversion point for illicit trafficking. Accordingly, any tracing system must account for the accurate recording of each firearm transfer between manufacturer and wholesaler or distributor and, subsequently, between retailer or dealer. Important considerations for the wholesaler and distributor, in addition to those of the record keeper, include:

- ensuring that accurate records are maintained during large shipments;
- establishing proper reporting and followup procedures when shipments fail to arrive or arrive incomplete.

It should be pointed that importers are crucial in the tracing process when they are required to impress an additional permanent marking to the firearm at the time of import. In the US, for example, importers are required to mark all imported firearms with a unique marking. (This mark is recorded.)

This system can expedite the tracing process because the marking provides an “update” on a firearm, especially where the firearms was not marked or poorly marked (as in older, used guns). Thus, a trace can commence from the record kept at the time of import, not from the time of manufacture. Therefore, the role of the importer as a key player in the tracing process must be acknowledged.

Dealers play a significant role in the tracing system because they sometimes represent the last recorded collection point for firearm information. In the US, for example, private transfers of firearms are not generally regulated, leaving the transfer from the dealer to the first retail buyer the last record of the firearm. While this system requires an often time-consuming investigative trace by individual law enforcement officials, it does not shift the burden of record-keeping to non-licensed persons, i.e., those not under regulation by the government. In other States, such as

Canada, nearly all transfers require an amendment of the firearms record, permitting a faster, more reliable and more accurate trace of the legal possessors of the firearms.

Certainly, to the extent that a State's constitution and legal system permits, firearms dealers do not need to be the final record keeper. As discussed *infra*, a tracing system benefits whereby accurate and comprehensive records are maintained by all the players in the chain of distribution.

4.3.2 Civilian Law Enforcement

As noted *supra*, a trace often begins with recovery of a crime gun by a local, regional or national law enforcement official. This action begins the task of identification of the firearm and its markings, a task requiring a fair degree of training and expertise. Depending upon the resources at their disposal, the law enforcement officials must be educated and well trained to complete a successful trace. It is not, however, necessary (and not practically feasible) for the law enforcement official to effectuate the trace itself. Rather, law enforcement must know how and when to contact the other players in the tracing circle. Thus, a law enforcement official can ordinarily submit a trace request to a specialist who will contact the manufacturer, wholesaler, distributor, retailer, purchaser or last known possessor and forward that information back to the officer. In other circumstances, the official may contact a central registry of firearms owners as a starting point for the investigation. In both cases, the role of the law enforcement official is to initiate the trace.⁹

4.3.3 Military Tracing Systems

The loss of military stockpiles of firearms (e.g., in the Balkans) in the last decade has proved the importance of establishing and maintaining a tracing system for all military small arms. Maintaining a separate military tracing system is advisable for several reasons, most notably the national security concerns of a transparent tracing system for military weapons. Such sensitivities are understandable and appropriate. However, the ready identification and tracing arms held by the State must be available on a case-by-case basis, so that States can identify and investigate losses and other States can combat illicit trafficking in such weapons.

4.3.4 Local, Regional, or National Tracing Centers

Tracing requires easy and prompt access to a large amount of firearms information. This access is efficiently accomplished by the centralization of records, either at the local, regional or national level. This can also be accomplished by coordination of a firearms trace by a single entity, regardless of where the records are maintained, provided the single entity has the means to immediately access the available records. ATF has established Regional Crime Gun Centers across the country. The Centers use a three-pronged strategy to reduce violent crime. The first strategy is to act as a central point to acquire information and intelligence. This involves the collection of ballistics and arrest reports involving crime guns for a specific area. The second strategy is the analysis of information and intelligence generated from the trace information along with the ballistics and arrest/complaint information. The third strategy is to function as a clearinghouse for requests and assistance to any federal, state, or local enforcement agency.

4.4 LOW-, MIDDLE- AND HIGH-COST OPTIONS FOR ESTABLISHMENT OF EFFECTIVE FIREARMS TRACING SYSTEM AND THEIR EFFECTIVENESS

4.4.1 Construction of a “Bare Bones” Tracing Mechanism

At a minimum, any effective tracing system must have four components:

- marking of all firearms at the time of manufacture;
- recording those markings at the point of manufacture and resale;
- making access to those records available to law enforcement;
- basic import/export controls.

This “bare bones” system in its earliest stage of evolution is not particularly costly. First, most modern firearms are already marked at the time of manufacture.¹⁰ Marking is achieved at a relatively low cost (estimated at a fraction of 1% of the cost of a firearm) and serves other purposes beyond traces (tax collection, inventory, quality control). Second, the recording can be done on paper, but it is recommended, for greater

accuracy and man-hour effectiveness, to record data in a computer (whose costs are reasonable for all manufacturers). Third, providing access to these records is of minimal cost to the manufacturer/wholesaler/dealer, but will require some expense for law enforcement or regulatory agencies to access the records (by phone, fax, or computer, or by mail or personal visitation). Finally, any effective training system requires that States establish minimal controls relating to the movement of uncontrolled firearms across their borders through a State.

4.4.2 A “Middle of the Road” Tracing System

Enhancements to “bare-bones” tracing systems can exponentially improve the tracing process and data retrieval capabilities. Such enhancements can include the following features:

- centralization of records;
- computerizing records;
- inauguration of data collection on used guns that have re-entered the commercial market;
- collection of crime gun data;
- expansion of access of law enforcement to the records.

Cost estimates of these enhancements naturally vary with the size and scope of the State in question, but the largest expense would be in the transition from paper records to computer storage systems. ATF’s process of digitizing paper records from out-of-business licensees will be fairly costly (approximately US\$15 million). The other enhancements are less costly but require legislative and regulatory changes.

4.4.3 A “Gold Standard” Tracing Mechanism

A third option would involve the use of all available technologies and resources to enhance the tracing process.

There are several marking innovations now available, though they are cost-prohibitive for general use. These technologies might be called “info-marking” (i.e., a general procedure in which the markings could provide a tremendous amount of information that is readily recorded or recordable). For example, the use of computer chips within a component part of the

firearm can provide instant information about the history of the firearm. The use of bar codes has also been explored.

Additional enhancements would include:

- web-based registration and tracing;
- web-based record-keeping for all manufactured, imported, exported and transferred firearms;
- widespread and improved Integrated Ballistics Technology;
- interoperability of tracing systems with other record-keeping systems such as fingerprint and DNA databases.

4.4.4 Inherent Impediments to an Effective Tracing System

No matter which tracing system is adopted, there will remain for the foreseeable future a number of impediments to successful traces. These include:

- the durability/longevity of firearms;
- the transportability of firearms;
- the large volume of extant firearms;
- the complexity of firearms models and types of marking systems, requiring the reliance upon experts;
- unmarked and improperly marked firearms;
- obliterated or sanitized markings;
- duplicate markings, or markings with unrecognizable symbols or letters;
- unauthorized and hence unrecorded transfers;
- stolen firearms;
- lost, damaged, or expired records;
- incompatibility of different tracing systems.

4.5 CONCLUSION

In countering firearms crime and violence, the value of tracing cannot be underestimated. Tracing not only furnishes law enforcement with the means to help solve a single crime, but uncovers illicit trafficking networks that can prevent new crimes from occurring. As shown in this paper, any effective tracing system must include the cooperative efforts of government and industry, working under an umbrella of clear laws, regulations and

industry practices. An effective tracing system does involve obvious financial costs, but the costs avoided from crimes not committed must also be considered, along with the social costs of violent crime. Tracing is a key weapon in fighting the battle against firearms violence.

Notes

- ¹ Sometimes a distinction is made between a firearms trace and an investigative trace. A firearms trace is often a trace by means of existing records, either kept electronically or manually on paper. An investigative search is distinguished by personal interviews or other investigative contacts with those individuals who may have possessed the firearm after it left the recorded chain of commerce. Accordingly, an investigative trace is more time and resource intensive.

It must also be noted that the tracing of firearms means tracing of crime guns. Guns are not ordinarily traced for commercial purposes but only in relation to a crime. Hence, one of the key reasons for tracing a firearm is to identify where the firearm was diverted from the legal to the illegal market. Such information is critical to prosecuting individuals who unlawfully possess or illicitly traffic firearms.
- ² This paper assumes that, absent a global unitary tracing system (an unlikely prospect in at least the near future), an effective tracing system will be both impeded by (due to incompatibility of tracing systems) and assisted by other existing tracing systems.
- ³ Richard F. Grimmett, "CRS Report for Congress: Conventional Arms Transfers to Developing Nations 1993-2000", Congressional Research Service, p. 75, Table 8D, 16 August 2001.
- ⁴ In similar fashion, the US military maintains its own tracking and tracing system for its firearms. For example, the US Army has established a Central Registry for all small arms in the Department of Defense arsenal. This registration, which is accomplished ordinarily through serial numbers, can track the weapon over its lifetime. As a result, the military is able to determine, "Who had it last?" and "Where has it been?"
- ⁵ See, for example, Articles VII and VIII to the Protocol. Similar language is used to require marking and record-keeping systems in the Organization of American States' Convention signed by the US.
- ⁶ See Article II, paragraphs 7 and 9.

- 7 Indeed, even within a single country, a trace can require contact with numerous individuals, from law enforcement officers, to firearms company employees to innocent purchasers.
- 8 Record-keeping is a good example where the participation of the industry can be quite beneficial. For example, many manufacturers maintain records indefinitely, despite the fact that a particular State's laws would not require indefinite retention. This point was made at the World Forum Sport Shooting Association Workshop, Sardinia, Italy, in 2000.
- 9 It is important to note here the value of comprehensive tracing, i.e., the tracing of *every* firearm recovered by law enforcement. Such comprehensive tracing is recommended for every police agency because of its value in identifying trafficking patterns, trends, crime guns of choice, corrupt retailers or others in the chain of distribution, etc.
- 10 It should be noted that there are a relatively small number of firearms enthusiasts and hobbyists who craft their own firearms "from scratch" and may not mark their weapons in accordance with the laws governing commercial and military manufacturers. Although it is impossible to determine the number of firearms thus created, it is believed to be fairly inconsequential compared to the number of firearms commercially produced each year (over 3 million in the US in 1998).

CHAPTER 5

SMALL ARMS AND LIGHT WEAPONS TRACEABILITY: A COMPARISON OF THE PRINCIPAL EXISTING INTERNATIONAL MECHANISMS

Michel Wéry and Ilhan Berkol¹

5.1 INTRODUCTION

It is currently impossible in most cases to trace small arms and light weapons (SALW), including ammunition and explosives. This is why the international community has begun in recent years to develop various mechanisms in an attempt to remedy the situation. These mechanisms are still far from allowing all weapons, ammunition and explosives to be traced effectively, however.

For the purposes of this study, the definition of traceability is understood to mean the capacity of the international community to reconstitute the entire route of a weapon, ammunition or explosive, from one owner to another and from the time it was manufactured to its last legal owner. Traceability, therefore, sheds light on the activities of traffickers, thereby allowing them to be pursued more effectively.

In order for a weapon, ammunition, or explosive to be traceable, three essential general preconditions are necessary:

1. **Marking:** the weapon must be marked appropriately so as to identify it in a unique and reliable manner at any time;
2. **Registration:** the original owner and all successive owners of the weapon (as well as transfers related to changes in ownership or location) must then be systematically recorded in an appropriate

manner in national (and possibly international) registers, which must also include the weapon's marking;

3. The tracing operation: in order to find the last legal owner of the weapon² and to reconstruct the course followed by the weapon, States must cooperate by exchanging information at their disposal concerning the weapon in question.

It should be noted that used alone, the term "tracing" can sometimes designate all three of these operations, or only the last two. In order to avoid confusion, we prefer to use other expressions such as "tracing operation" or "exchange of information required for tracing" to describe the third operation.

The purpose of this study is to provide a clear summary of the main mechanisms and initiatives that currently exist with respect to tracing, and to compare them.

We begin by presenting and comparing the main existing international and (sub-)regional mechanisms (Section 5.2). They have all been selected for their legally-binding nature or because of the fact that they impose certain obligations on States. It should be noted, however, that some of them have not yet entered into force:

1. Protocol against the Illicit Manufacturing of and Trafficking in Firearms, Their Parts and Components and Ammunition, supplementing the United Nations Convention against Transnational Organized Crime)³ (hereafter referred to as the "Vienna Protocol");
2. The UN Programme of Action to Prevent, Combat and Eradicate the Illicit Trade in Small Arms and Light Weapons in All Its Aspects⁴ (hereafter referred to as the "UN Programme of Action");
3. The Convention on the Marking of Plastic Explosives for the Purpose of Detection⁵ (hereafter referred to as the "Plastic Explosives Convention");
4. The European Agreement for the Transport of Dangerous Goods by Road (ADR) and the UN Model Regulations on the Transport of Dangerous Goods⁶ (hereafter referred to as the "International regulations on the transport of dangerous goods");
5. The Convention of the Organization of American States Against Illicit Firearms Trafficking⁷ (hereafter referred to as the "OAS Convention");

6. The Protocol on the Control of Firearms, Ammunition and Other Related Materials, in the Region of the Southern African Development Community⁸ (hereafter referred to as the “SADC Protocol”);
7. The OSCE Document on Small Arms and Light Weapons⁹ (hereafter referred to as the “OSCE Document”).

These mechanisms will then be compared with the “desirable system”—a theoretical model proposed by the authors of this paper—which combines a certain amount of ambition, indispensable to the creation of an effective system, and realism as to its technical feasibility.

In Section 5.3 we present the contents of five other important—though not binding—initiatives. This will complete the picture and provide a wider perspective of the main political positions and dynamics animating the debate on SALW tracing.

Finally, Section 5.4 consists of a study of the possibilities for synergies between the existing regional and international mechanisms and of the opportunity for creating a new international tracing mechanism.

5.2 COMPARISON OF THE PRINCIPAL EXISTING MECHANISMS

5.2.1 Scope and Field of Application of Existing Mechanisms

The desirable system

Scope:

- A legally-binding mechanism that is global in scope.

Field of application:

- Applicable to all SALW (including ammunition and explosives), licit and illicit,¹⁰ irrespective of the purchasers or sellers involved;
- It is highly desirable that ammunition and explosives be included in the mechanism, given their strategic importance in conflicts on the one hand, and the serious difficulties currently encountered pertaining to their traceability, on the other;
- States implement measures that allow State-owned weapon stockpiles to be marked and registered according to the new standards (with no obligation to include security markings, however) in the course of

routine stockpile management. A 10-year deadline would be given to allow the new standards for marking and registration to be applied to all weapons manufactured prior to the implementation of the mechanism.¹¹

Vienna Protocol

Scope:

- Mechanism that is legally-binding for States that have ratified it and the Convention against Transnational Organized Crime.¹² As the minimum number of 40 ratifications has not yet been reached, however, neither of these two instruments has entered into force. As of 6 November 2002, 46 States had signed the Protocol and three (Bulgaria, Burkina Faso, Mali) had ratified it;
- Potentially global in scope;
- The Vienna Protocol must therefore be taken into consideration in the elaboration of an international tracing mechanism.

Field of application:

- The “firearms” covered by the Vienna Protocol include all portable barrelled weapons, with the exception of those manufactured prior to 1899, or in other words almost all SALW strictly speaking,¹⁴ as well as their parts, components and ammunition (Article 3.a). Ammunition, however, is excluded from all the provisions concerning traceability, and explosives fall outside the field of application of the Protocol;
- The Protocol does not apply to transactions between States when national security is at stake (Article 4.2.);¹⁵
- Investigations and legal proceedings are initiated only in the case of offences that are of a transnational nature and which involve an organized criminal group (Article 4.2.).

UN Programme of Action

Scope:

- Politically-binding mechanism, global in scope;
- Adopted by consensus at the UN on 21 July 2001;
- The objective of the UN Programme of Action was to establish a framework from which concrete measures at national, (sub-)regional and international levels will be drawn up;
- Two important articles should be pointed out:

- (i) A recommendation to the General Assembly to undertake a study to examine the possibility of developing an international instrument to enable States to identify and trace illicit small arms and light weapons in a timely and reliable manner (Article IV.1.c.). A group of governmental experts is formed for this purpose,¹⁶ and will submit a report in September 2003 at the latest.
- (ii) The encouragement of negotiations, where appropriate, with the aim of concluding relevant legally-binding instruments in order to prevent, combat and eliminate illicit trade in SALW in all its aspects and, where they do exist to ratify and fully implement them (Article II.25).

Field of application:

- The UN Programme of Action¹⁷ does not specify which definition of small arms¹⁸ applies; however, during the negotiations it was said that the prior work of the three groups of experts on the matter constituted the background for the UN Programme of Action, and the first of these defines SALW as weapons that can be carried by a person or light vehicle, and whose calibre is less than 100 millimetres, as well as their ammunition and explosives. This is a very broad definition;
- The traceability objective is much broader than that targeted by the Vienna Protocol. Here, it is no longer a question of combatting transnational organized crime, but of combatting all types of arms trafficking.

Plastic Explosives Convention

Scope:

- This international Convention was signed in 1991 in the wake of the Lockerbie incident and entered into force on 21 June 1998. It is applicable to all States that have ratified it;¹⁹
- It is a legally-binding mechanism.

Field of application:

- This Convention applies to all plastic and sheet explosives described in the technical appendix.²⁰

International regulations on the transport of dangerous goods

Scope:

- A vast array of regulations, the primary objective of which are to guarantee public security. In brief, the UN Model Regulations have existed since 1996, and are updated twice annually by a Committee of Experts. They apply to four areas: transportation by road, by rail, by sea and by air;
- As part of this system, the regulations concerning seaborne and air transport have been internationally accepted. Furthermore, an agreement on road transportation among 40 European nations (including the Russian Federation) has been in effect since 1968. It led notably to a European Directive for the member States of the EU in 1994;
- The provisions of these regulations have been transposed into the national legislation of numerous States, both members and non-members of the EU, and have become legally-binding.

Field of application:

- Applies to all ammunition and explosives.

OAS Convention

Scope:

- This Convention, which was adopted in 1997, entered into force on 1 July 1998. It is applicable to all States that have ratified it. A consultative committee monitors its application in the member States. As of 6 November 2002, 33 countries had signed the Convention and 16 had ratified it (it should be noted that the US and Canada are among the States that have not ratified the Convention);
- It is a legally-binding mechanism.

Field of application:

- The Convention applies to all barrelled firearms²¹ manufactured after 1901;
- *De facto*, the provisions concerning traceability do not concern ammunition, nor do they concern explosives in a way that truly binds States.

SADC Protocol

Scope:

- This mechanism, which was adopted on 14 August 2001, has not yet entered into force. It will be applicable to all States of the SADC (14 countries of Southern Africa) that have ratified it. It has so far been ratified by four States;
- It is a legally-binding mechanism.

Field of application:

- This Protocol applies to “firearms” with a calibre of less than 100 mm, with the exception of antique weapons;²²
- Ammunition and explosives are excluded from the provisions dealing with traceability.

OSCE Document

Scope:

- Mechanism adopted on 24 November 2000 and is applicable to the member States of the OSCE;
- It is politically-binding (Article VI.6.).

Field of application:

- This mechanism applies to “small arms and light weapons”,²³ which are defined as portable weapons manufactured and designed for military use. This restriction to military weapons appears to be more a function of the philosophy of the OSCE as an international security organization than a deliberate attempt to exclude civilian weapons from the field of application.²⁴ Moreover, the term “small arms” is used throughout the document, but the expression definitely refers to “small arms and light weapons” (Article 3 of the Preamble);
- Ammunition and explosives are nevertheless excluded from the provisions that concern traceability.

Comparison:

1. Thus, there are seven international and regional mechanisms, two of which bind States politically, while the other five bind them legally. Among the latter group, the Vienna Protocol and the SADC Protocol have not yet entered into force;

2. The definitions of weapons, ammunition and explosives concerned by these mechanisms vary considerably. Nevertheless, there is no real contradiction among them—some are simply broader than others;
3. Five of the mechanisms concern essentially or only firearms; one concerns ammunition and explosives; and another deals exclusively with explosives. It is interesting to note that when these definitions are “added together” they cover the entire range of SALW, including ammunition and explosives—with the exception of antique weapons—which brings us close to the desirable system described at the beginning of this section.

5.2.2 Provisions Concerning Marking

*The desirable system*²⁵

- “Adequate” marking includes a unique serial number, an identifying mark of the manufacturer, a country identifier and the year of manufacture (e.g.: 12345678-FN-BE-01);
- Each weapon has an adequate classic marking,²⁶ which is applied to a maximum number of important components,²⁷ and expressed in alphanumeric language. A 10-year deadline is nevertheless granted for the adequate classic marking to be applied to weapons that were manufactured before the mechanism entered into force. Nevertheless, in order to be transferred, these weapons must be marked and registered according to the new system;
- Every State importing a weapon that does not have adequate marking:
(i) applies adequate classic marking to the weapon if it was manufactured prior to the entry into force of the mechanism; (ii) destroys it if it was manufactured after this date (given that it would therefore be an illicit weapon);
- Every State importing an adequately marked weapon affixes, at a certain distance from the main marking, two letters that allow the importing country to be identified, and two numbers for the year of import (e.g.: 12345678-FN-BE-01 **BR-02**: a weapon produced in Belgium by the company FN in 2001, and then imported by Brazil in 2002). As explained in the section “Comparison” that follows, this measure is foreseen in the Vienna Protocol and facilitates and increases the chances of successful tracing;

- Classic marking has the advantage of being easy to read, but it is also easily obliterated. In order to counter this problem, all newly manufactured weapons also have an “adequate security” marking, the contents of which can be read by specialized institutions when the classical marking has been erased. This security marking is indelible or very difficult to erase,²⁸ and is produced by means of a technique that is simple and inexpensive.²⁹
- All ammunition of the same batch and all explosives of the same batch have a marking that mentions a unique batch number;³⁰
- Firearms, ammunition and explosives that do not meet the above standards are declared illicit. All illicit weapons are destroyed, as foreseen in the OSCE Document.

The Vienna Protocol

- During the manufacturing process, all concerned firearms are tagged with: (i) either a unique marking, which includes a unique serial number, the country or place of manufacture and the name of the manufacturer, (ii) or any alternative unique and user-friendly marking with simple geometric symbols³¹ in combination with a code permitting all States to easily identify the country of manufacture (Article 8.1.a).
- On each imported weapon, the following is applied: (i) a simple marking permitting the identification of the country of import, and, if possible, the year of import. This principle is however not applicable to temporary imports (Article 8.1.b); (ii) a unique marking if the firearm does not bear such a marking;
- When State stockpiles are transferred to the civilian market, an appropriate and unique marking is applied that permits the identification of the transferring country (Article 8.1.c);
- States encourage the arms industry to develop measures against the removal or alteration of markings (Article 8.2.).

The UN Programme of Action

- Each State ensures that licensed manufacturers undertake, during the manufacturing process, to reliably mark all small arms permitting the identification of the country of manufacture. The marking must also

enable national authorities to identify the serial number and the manufacturer, so that each weapon can be traced (Article II.7.);³²

- Each State furthermore ensures that it prevents the manufacture, stockpiling, transfer and possession of firearms that do not bear adequate marking (Article II.8.);
- States are encouraged to exchange information on their marking systems (Article III.12.).

*The Plastic Explosives Convention*³³

- All newly manufactured explosives covered by this Convention must be marked by each State, by means of detecting agents described in the technical Annex (Articles 1 and 2). This marking aims to permit the detection of the presence of explosives, and not their tracing;
- Explosives manufactured prior to the entry into force of the Convention cannot be held, displaced and transferred unless under the strict and effective control of the States—in order to prevent their being used for purposes not in conformity with the objective of prevention of terrorism (Articles 3 and 4.1.). Those explosives still existing 15 years following the entry into force of the Convention must be destroyed, consumed or marked (Article 4.3.);
- All stockpiles of explosives not belonging to police or security forces are to be destroyed, consumed or marked within a three-year period (Article 4.2.);
- In collaboration with the States parties and the relevant international organizations, the Council will take the appropriate measures to provide technical assistance and to exchange information relating to marking and detection techniques of explosives (Article 9.).

International regulations on the transport of dangerous goods

- All packaging containing ammunition and explosives shall be marked in a legible and durable manner. In the case of containers, the elements of the contents must also be marked;
- These markings notably comprise the following data: a unique serial number, the State issuing the certificate authorizing the transport, the firm requesting the certificate, the year, and the weight of the packaging;
- In accordance with the recommendations of the UN, controls must be undertaken by a party outside the firm, notably concerning the

legibility and durability of the marking and its content, at least once a year. The manufacturers may choose the verifying body, and in the EU, there is at least one organization in each country. In addition, manufacturers must systematically carry out internal controls.

The OAS Convention

- Newly manufactured firearms must be marked with the name of the manufacturer, the place of manufacture and the serial number (Article VI.1.a);
- Imported firearms must be marked to permit the identification of the name and address of the importer (Article VI.1.b.);
- Firearms that have been confiscated and retained for official use must be marked appropriately (Article VI.1.c);
- Explosives and rocket launchers should, if possible, must be marked at time of manufacture (Article VI.2.).

The SADC Protocol

- States parties undertake to establish common systems to ensure that all firearms are marked with a unique number, at the time of manufacture or import, on the barrel, frame, and, where applicable, the slide (Article 9.1.);
- This marking shall identify the country of manufacture, the serial number and the manufacturer of the firearm (Article 9.2.).

The OSCE Document

- It is incumbent on each participating State to determine the exact nature of the marking system for small arms manufactured or in use on its territory (Article II.2.B.1.). However, the States simultaneously endeavour to develop standards, principles and measures concerning appropriate marking (as well as durable and precise registration) in international fora (Article I.2.);
- The participating States agree to ensure that all small arms manufactured on their territory after 30 June 2001 are marked so as to enable individual small arms to be traced. The marking should contain information that allows the investigating authorities to determine at least the year and country of manufacture, the manufacturer and the

serial number of the firearm. This information provides an identifying mark specific to each small arm (Article II.2.B.1.);

- All such marks should be permanent and placed on the firearm at the site of manufacture (Article II.2.B.1.);
- The participating States will not allow any transfer of unmarked small arms. Moreover, they will only transfer or re-transfer small arms bearing a unique marking (Article III.B.7.);
- The participating States ensure, as far as possible and within their competence, that all small arms manufactured under their authority outside their territory are marked to the same standard (Article II.2.B.1.);
- Should unmarked firearms be discovered in the course of routine management of existing stockpiles, the participating States will destroy them, or, if these weapons are brought into service or exported, they will mark them beforehand with an identifying mark specific to each small arm (Article II.2.B.2.);
- The participating States agree to conduct before 30 June 2001 an exchange of information on their national marking systems used in the manufacture and/or importation, and they will update this information to reflect any change in their national marking systems (Article II.2.D.1.).

Comparison:

1. Contents of the information marked during the manufacturing process: most of the mechanisms explicitly foresee a unique serial number, country and manufacturer identifiers. The OSCE Document is the only one to also foresee an indication of the year of manufacture. The mention of the year is nevertheless crucial to be able to differentiate weapons manufactured before the entry into force of the mechanism from those manufactured subsequently, and which come therefore within the provisions of its application;
2. Standards for marking imported firearms: the Vienna Protocol and the OAS Convention both foresee marking upon import; the former simply mentions the importing State and the year, while the second permits the precise identification of the importer. These markings, and in particular the simple marking that clearly indicates the country of import, greatly facilitate the stages of the tracing operation by permitting one to read directly on the firearm the countries into which it has previously been imported. An investigator can then simply turn

to the last importer indicated on the arm rather than having to trace back to the manufacturer and reconstitute all the stages of the weapon's life.³⁴

3. Legibility: only the Vienna Protocol specifies the way in which the "classical" marking is to be expressed, and in this context stipulates the option for certain States to use symbols—which hinders the registration and exchange of information. It is important that all the mechanisms be precise on this subject (this would require the introduction of a relevant amendment for the existing mechanisms, and the exact specification of requirements at the outset of possible future mechanisms).
4. Only the SADC Protocol foresees the obligation to mark several parts of firearms. This measure, already applied without obligation by some manufacturers, must be brought into wide use.
5. Durability: only the Vienna Protocol takes into account the problem of the ease with which traffickers can erase the markings on firearms.³⁵ Frequent obliteration of markings justifies the systematic application of security markings.
6. Concerning firearms manufactured prior to the entry into force of the respective mechanisms: the Vienna Protocol foresees the marking of weapons transferred to civilians by a State; the OAS Convention foresees the marking of confiscated weapons that would be transferred to police and security forces; and the Plastic Explosives Convention foresees the marking, consumption or destruction of unmarked explosives within a certain timeframe.
7. Extraterritoriality: only the OSCE Document foresees marking "as far as possible and within the limits of the competence of the States" of firearms that are manufactured under a State's authority but outside its territory.
8. Ammunition: the recommendations on the transport of dangerous goods foresee the marking of all ammunition packaging in a unique and detailed manner. The absence of unique marking on the ammunition itself is evidently a problem since traffickers can merely transfer the contents into another packaging. This mechanism nevertheless has other interesting aspects: for one, the content of the marking is quite exhaustive and almost indelible. Furthermore, in consenting to improving the traceability of ammunition (and of explosives) packaging, States have implicitly consented to give up a certain degree of confidentiality, since the verification of packaging allows the contents to be known by the controlling organization.

9. Explosives: the recommendations on the transport of dangerous goods foresee the marking of all explosives packaging, as above. In addition, the Plastic Explosives Convention foresees that States parties mark individually all newly manufactured plastic and sheet explosives.

5.2.3 Provisions Concerning Registration and Data Conservation

The desirable system

- Each State appoints or creates a body to manage a computerized national record, in which are recorded all small arms (including ammunition and explosives) irrespective of their owners and irrespective, if applicable, of the transaction in which they are involved (transfer, acquisition, sale or transportation). This body is also responsible for controlling markings and registration on the ground;
- The data recorded includes the following: date of registration, description and quantity of the firearms, ammunition or explosives concerned, the data contained in the marking, the former and current owner, as well as, if applicable: brokers and transportation services, importing, exporting and transit countries; final recipient; and dates of issue and expiry of the requested licences or authorizations;
- The data is conserved until the firearms, ammunition or explosives concerned fall into the category of antique weapons, according to a globally accepted standard.³⁶

The Vienna Protocol

- Each State ensures that the information on the firearms is maintained for at least 10 years and, where appropriate and feasible, their parts and components and ammunition necessary to ensure the tracing of illicit firearms (Article 7);
- The recorded information includes: (a) the marks required by Article 8, and (b) in cases involving international transactions in firearms, their parts, components and ammunition, the dates of issue and expiration of the appropriate licences and authorizations, the country of export, import and transit, the final recipient as well as the description and quantity of the articles (Article 7.b).

The UN Programme of Action

- The States ensure that complete and precise records concerning the manufacture, holding and transfer of SALW in areas under national jurisdiction are conserved for as long as possible. These records must be organized and maintained so as to allow the competent national authorities to rapidly retrieve accurate information from them and collate it (Article II.9.).

The Plastic Explosives Convention

- Contains no provisions relative to the registration and conservation of data.

International regulations on the transport of dangerous goods

- All documents dealing with verification, and including notably those concerning marking, must be maintained for at least five years by the manufacturer.³⁷ The verifying bodies must conserve this same information as long as the type of packaging remains in use, after which they must be filed;
- The authorities do not maintain copies of this information, but the verifying bodies are obliged to transmit it to them upon request;
- It should be noted that the Verification Institutes of three European countries have taken steps amongst themselves and with the EU to establish a database that places their information at the disposal of the European Institutes.³⁸ This initiative could be the beginning of a wider data exchange system.

The OAS Convention

- The States parties shall assure the maintenance for a reasonable time of the information necessary to trace and identify illicit firearms, to enable them to comply with their obligations relative to exchange of information and mutual assistance (Article XI).

The SADC Protocol

- The States parties undertake to keep proper records of the markings applied to firearms (Article 9.1.);

- The States parties undertake to establish and maintain complete national inventories of firearms, ammunition and other related materials held by security forces and other State bodies (Article 8.a);
- The States parties incorporate as a priority into their national laws and the regulation and centralized registration of all civilian owned firearms in their territories (Article 5.3.d);
- States parties undertake to consider a coordinated review of national procedures and criteria for (...) establishing and maintaining national electronic databases of licensed firearms , firearm owners, and brokers within their territories (Article 7);
- The States parties undertake to improve the capacity of the police forces, customs, border guards, army, judiciary and other relevant agencies to fulfil their roles (...) establishing and improving national databases (...) (Article 6.b etc.);
- The States parties undertake to establish national databases to facilitate the exchange of information relative to importing, exporting and transfers (Article 16.b).

The OSCE Document

- The participating States shall ensure that accurate and detailed records of their own holdings of small arms within their territory are maintained and held as long as possible with a view of improving small arms traceability (Article II.2.C.). The participating States shall ensure furthermore that their stockpiles are subject to proper inventory and control (Article IV.B.1.);
- They furthermore undertake to adopt and apply national measures of control for these records and (Article I.3.i), to develop norms, principles and measures in this area, based on the concept of cooperative security of the OSCE, and acting in concert with other international authorities (Article I.2.).

Comparison:

1. Recorded data: most of the mechanisms establish general rules such as “comprehensive and accurate records”, “precise and detailed”, or “with necessary information to trace” firearms. The Protocol is more accurate in this regard, as it provides details about the data to be recorded. It would be worthwhile to set precise common standards for registration, especially for the purposes of increasing the efficiency and

harmonization of data exchange during tracing operations, similar to the way it is done within Interpol (see section 5.3);

2. Duration of data maintenance: here again, most of the mechanisms set out only general stipulations, such as: “as long as possible” or “for a reasonable period of time”. Only the Vienna Protocol sets the precise standard of a minimum of 10 years, but this standard seems largely insufficient considering the average lifespan of a weapon, which can easily reach up to 50 years if it is well maintained. There is a good reason why all the mechanisms studied here exclude only antique weapons;
3. National records: all the mechanisms foresee the keeping of records; however, with the exception of the SADC Protocol, they do not explicitly stipulate that records must be centralized on a national scale. As pointed out in the next section (which studies the tracing operation), however, most of the mechanisms foresee that each State has only one point of contact for information exchange. It therefore appears logical, for obvious reasons of efficiency and optimal use of resources, that each national point of contact should include a centralized national register;
4. The SADC Protocol, the OSCE Document and the Vienna Protocol³⁹ all foresee measures for marking and registering existing firearms within the possession of law enforcement bodies, civilians and/or during the transfer of State-owned stockpiles to civilians.

5.2.4 Provisions Relative to the Exchange of Data Needed in Tracing Operations

The desirable system

- In each State, the body responsible for maintaining the national register is the national point of contact, or is very closely linked to it. This body is in charge of exchanging the information necessary for tracing operations with the points of contact of other States or regions and with other relevant organizations;
- Tracing operations apply to at least all small arms that have become illicit (ammunition and explosives included);
- There are no restrictions concerning the exchange of data, and this includes all States⁴⁰
- The exchange of data is accurate, rapid, and carried out using standardized documents;

- The following is established within the UN framework:
 - either a centralized international small arms register (including ammunition and explosives) to which each State shall transmit on a regular basis all data contained in its national register, or
 - an international agency that would be responsible for requesting from States, through their national points of contact, the transmission of the data necessary for conducting tracing operations.

Advantages: (i) faster and more efficient tracing, given that it would be better coordinated; (ii) possibility of crosschecking the information between different tracing operations, permitting the identification of routes customarily used by traffickers; and, moreover, (iii) in the case of the international register, the risks due to accidental data loss in one of the States would be minimized.

The degree of transparency to which States are prepared to consent determines the modalities for confidentiality of each system.

The Vienna Protocol

- The term “tracing” means the systematic tracking of the transfer of firearms, and where possible, of their parts, components and ammunition from manufacturer to purchaser for the purpose of assisting the competent authorities of States parties in detecting, investigating and analyzing illicit manufacturing and trafficking (Article 3 f);
- The States parties agree to cooperate in the tracing of firearms, their parts, components and ammunition that may have been illicitly manufactured or trafficked, and to respond promptly, within the limits of their means, to requests for assistance in this domain (Article 12.4.);
- Each State party shall also identify a national body or a single point of contact to act as liaison with the other State parties for questions relative to the Protocol (Article 13.2.);⁴¹
- The States parties exchange, consistent with their respective legal and administrative systems, relevant information concerning (...) the routes customarily used by organized criminal groups engaged in e illicit trafficking in firearms, their parts, components and ammunition (Article 12.2.c);⁴²
- Subject to the basic concepts of its legal system or any international agreements, each State party receiving information from another State

party guarantees its confidentiality and complies with any restrictions regarding its use, if requested to do so (Article 12.5.).

The UN Programme of Action

- At the global level, the States undertake to strengthen their ability to cooperate in order to identify and trace illicit SALW in a timely and reliable manner (Article II. 36.);
- The States undertake to cooperate with each other (...) and, where appropriate, with relevant international, regional and intergovernmental organizations in tracing illicit SALW, in particular by strengthening mechanisms based on the exchange of relevant information (Article III. 11.);
- The States undertake to establish or designate, where appropriate, a point of contact at the national level to act as liaison between States on matters relating to the implementation of the UN Programme of Action (Article II.5.);
- The States undertake to establish or designate, where appropriate, points of contact within sub-regional and regional organizations to act as liaison on matters relating to the implementation of the UN Programme of Action (Article II. 24.). All the information is collated and circulated by the UN Secretary-General (Article II.33.);
- The States voluntarily submit to relevant regional and international organizations, particularly the information relating to the routes used by traffickers (Article II.23.);
- The States undertake to establish, where appropriate, sub-regional and regional mechanisms, and in particular to set up networks for information-sharing among law enforcement, border controls and customs agencies (Article II.27.);
- The States, the World Customs Organization, and other relevant organizations are encouraged to enhance their cooperation with Interpol⁴³ in order to identify the groups and individuals engaged in the illicit trade of small arms in all its aspects (Article II. 37).

The Plastics Explosives Convention

- Contains no provisions relating to information exchange to allow for tracing. There are, however, provisions relative to the exchange of information with respect to national practices, with a view to facilitating harmonization (Articles 8.2. and 9).

International regulations on the transport of dangerous goods

- New tracing techniques have been developed with the introduction of electronic chips that contain notably the serial number. Packaging bearing these chips can be located at any time by radio transmission.

The OAS Convention

- The States parties shall cooperate at the bilateral, regional and international levels to prevent, combat and eradicate the illicit manufacturing of and trafficking in firearms, ammunition, explosives and other related materials (Article XIV.1.);
- The States parties shall cooperate in the tracing of firearms, ammunition, explosives and other related materials which may have been illicitly manufactured or trafficked. Such cooperation includes accurate and prompt responses to tracing requests (Article XIII. 3.);
- The States parties shall afford one another the widest mutual legal assistance, in conformity with their domestic law and applicable treaties, by promptly and accurately processing and responding to requests from authorities which, in accordance with their domestic law, have the power to investigate or prosecute illicit activities (Article XVII.1.). In this context, the States parties shall appoint a national body or a single point of contact to act as liaison among States parties, as well as between them and the Consultative Committee established in article XX, for purposes of cooperation and information exchange (Article XIV.2.);
- The States parties shall exchange relevant information concerning the routes customarily used by traffickers in firearms, ammunition or explosives (Article XIII.1.c), concerning the authorized manufacturers, brokers, importers and exporters, and whenever possible, carriers (Article XIII.1.a);
- The States parties shall cooperate with each other and with competent international organizations to ensure that their personnel is adequately trained on all the aspects relating to traceability (Article XV.2.);
- Subject to the obligations imposed by their Constitutions or any international agreements, the States parties shall guarantee the confidentiality of any information they receive if the State supplying the information so requests. If, for legal reasons, such confidentiality cannot be maintained, the State party that provided the information must be notified prior to its disclosure (Article XII).

The SADC Protocol

- The States parties shall establish appropriate mechanisms for cooperation among respective executive bodies to promote effective implementation of this Protocol, notably by: (a) establishing direct communication systems to facilitate fast and free flow of information; (...) (d) promoting cooperation with international organizations such as Interpol and the World Customs Organization, and using existing data bases such as the Interpol Weapons and Explosives Tracing System; (e) establishing national points of contact within the respective executive bodies for the rapid exchange of information to combat cross-border firearm trafficking (Article 15.);
- The States parties shall cooperate with each other to afford mutual legal assistance in a concerted effort to prevent, combat and eradicate the illicit manufacturing, trafficking, possession and use of firearms, ammunition and other related materials, as well as their excessive and destabilizing accumulation (Article 14.1.). This mutual assistance includes, among other things: (a) the communication of information and the transfer of exhibits; (b) the investigation and detection of offences; (...); (h) the communication of relevant documents and recorded data; (i) the identification or tracing of suspects (Article 14.2.);
- The States parties undertake to develop and improve transparency with respect to the accumulation and flows of firearms, as well as to the policies they apply to civilians (Article 16. a).

The OSCE Document

- The participating States agree to cooperate with each other, as well as with intergovernmental organizations such as Interpol to locate illegal small arms. In the context of this cooperation, they shall communicate upon request any relevant information to the investigating authorities other participating States (Article III.E.4.);
- The participating States agree to share information, in a confidential manner, on seizures of illicit small arms, notably the quantity and type of weapons seized, their markings, and details of their subsequent disposal (Article III.E.6.ii);
- The participating States agree to the establishment and maintenance of a list of national points of contact in charge of matters concerning small arms (Article VI.1.);

- The participating States agree to examine means of improving the exchange of information on small arms transfers, in addition to information relating to their export and import (Article III. E1.).

Comparison:

1. In addition to the principle of cooperation, all the mechanisms, with the exception of the Protocol on the marking of explosives and the recommendations on the transport of dangerous goods, foresee the implementation of a national point of contact to exchange information. The UN Programme of Action also foresees points of contact for each region and sub-region. This practical aspect is crucial for effective cooperation;
2. Most of the mechanisms specify that information exchange must be rapid and accurate, with the exception of the OSCE Document and the Plastic Explosives Convention. The SADC Protocol also foresees the implementation of concrete measures to facilitate the efficiency of these exchanges. The OSCE Document further insists on the training of personnel in charge of all the aspects related to traceability;
3. Most of the mechanisms specify that information exchange concerns all illicit weapons;
4. The Vienna Protocol, the OAS Convention and the OSCE Document stipulate that information exchanged is confidential. This, however, is a general principle, and in the case of the first two aforementioned mechanisms exceptions may apply;
5. Further to enhancing information exchange and bilateral cooperation, many mechanisms foresee extending this through the inclusion of relevant regional and international organizations;
6. No mechanism foresees an international register of small arms transfers, or an international institution that would coordinate tracing operations. The Interpol Weapons and Explosives Tracing System (IWETS), described in section 5.3.4, nevertheless represents an example of a mechanism that centralizes information.

5.2.5 Penal Clauses

The desirable system

- Weapons, ammunition or explosives that do not bear adequate markings or which are not adequately registered according to the

norms of the desirable system described in sections 5.2.2 and 5.2.3, are to be considered illegal;

- Their manufacture, transfer, acquisition, sale, transportation or possession are punishable by law, unless the person responsible can prove that the act was not intentional;
- Each State confers the status of criminal offence on illicit manufacturing, illicit trafficking, as well as falsification, obliteration, removal or alteration of markings;
- The States shall adopt the necessary measures to make provisions in their laws to sanction offences committed by foreigners on their national territory, or committed abroad by their nationals or by individuals habitually residing on their national territory.

The Vienna Protocol

- “Illicit trafficking” signifies the import, export, acquisition, sale, delivery, transportation or transfer of firearms, components, parts or ammunition when they are not marked in conformity with the present Protocol (Article 3.e), and “illicit manufacture” signifies the manufacturing of firearms, components, parts or ammunition not marked in conformity with the present Protocol (Article 3.d);
- Each State confers the status of criminal offence on illicit manufacturing and illicit trafficking when they have been intentionally committed, as well as on falsification, obliteration, removal or alteration of markings (Article 5.1.). The fact of being an accomplice to such acts, or otherwise organizing, directing, facilitating, abetting or promoting such acts by means of assistance or advice shall also be considered a criminal offence (Article 5.2.).

UN Programme of Action

- To adopt where they do not exist, and enforce, all the necessary measures to prevent the manufacture, stockpiling, transfer and possession of any unmarked or insufficiently marked firearm (Article II. 8.);
- To adopt and implement, in the States that have not already done so, the necessary legislative or other measures, to establish as criminal offences under their domestic law the illicit manufacture, possession, stockpiling and trade of SALW (Article II.3.).

The Convention on Plastic Explosives

- Each State party shall take the necessary and effective measures to prohibit and to prevent: (i) the manufacture on its territory of unmarked explosives (Article 2), and (ii) the movement of unmarked explosives into or out of its territory, unless it takes place in the context of military or police functions (Articles 3.1. and 3.2.);
- Each State party shall ensure the destruction, as soon as possible, of unmarked explosives that are discovered, other than those that come under a series of exceptions foreseen in the Convention (Articles 4.4. and 4.6.).

The International regulations on the transport of dangerous goods

- The manufacturers are responsible for packaging ammunition, explosives and other dangerous materials in accordance with the applicable recommendations, and especially for applying appropriate markings and keeping records for a minimum of five years. Adequate markings are necessary for the transport of dangerous goods, and this is particularly required by customers;
- External checks are carried out at least once a year by an authorized institution. In certain countries, such as Belgium, when an offence is observed, all packaging produced since the last control are verified. Non-conform packaging is then destroyed.

The OAS Convention

- The States parties that have not yet done so shall adopt the necessary legislative and other measures to establish as criminal offences under their domestic law the illicit manufacturing of and trafficking in firearms, ammunition, explosives and other related materials (Article IV.1.). These offences shall be included in any extradition treaty in force between the State parties (Article XIX.2.);
- The States shall adopt the necessary measures to establish its jurisdiction for the offences: (i) committed in its national territory (obligatory); (ii) committed by one of its nationals or by a person who habitually resides in its national territory (not obligatory) and; (iii) when the suspect is present in its territory and it does not extradite because of the nationality (obligatory) (Articles V.1, 2 and 3).

The SADC Protocol

- The State parties shall enact the necessary legislation and take other measures to establish as criminal offences, in order to prevent, combat, and eradicate the illicit manufacturing of firearms, ammunition and other related materials, and their excessive and destabilizing accumulation, trafficking, possession and use (Article 5.1.).⁴⁴

The OSCE Document

- The participating States shall ensure that those engaged in illegal production can, and will, be prosecuted under appropriated penal codes (Article II.2.A.). However, the manufacture of unmarked weapons is not explicitly considered as being illegal.

Comparison:

1. Most of the mechanisms foresee sanctions in the case of the manufacture and trade (as well as of other illicit transactions) of firearms and/or ammunition and explosives. Some of them specify that the manufacture of and transactions involving firearms, ammunition and/or explosives that are not marked appropriately are considered illicit, and are therefore subject to the application of these sanctions;
2. The Vienna Protocol also confers the status of criminal offence on the falsification, obliteration, removal or alteration of the markings, as well as on numerous forms of complicity, assistance or abetting in these offences;
3. The OSCE Document foresees the enforcement of extraterritoriality in offences related to the illegal manufacture of small arms.

5.3 OTHER IMPORTANT INITIATIVES

In this section, we present five initiatives that are neither politically- nor legally-binding, but which are important and broaden our knowledge of the current political positions, on the one hand, and on some of the existing mechanisms on the other.

5.3.1 European Joint Action

The Joint Action of 17 December 1998, relative to “the EU’s contribution to combating the destabilising accumulation and spread of small arms and light weapons”⁴⁵ does not contain any binding provisions with respect to traceability. Article 3, which deals with aspects related to this, stipulates only that “the EU aim at building consensus in the relevant international forums, and in a regional context as appropriate”. As such, this initiative simply promotes a policy with respect to those outside the Union and with respect to the member States, “for the realisation of the following principles and measures”:

- In order to ensure control, the establishment and maintenance of national inventories of legally-held weapons owned by the country’s authorities (Article 3.d);
- The commitment to combat illicit trafficking of small arms through regional and international cooperation and enhanced information exchange (Article 3.f);
- The establishment of confidence building measures, including measures to promote increased transparency and openness, through regional registers on small arms and regular exchanges of available information, on exports, imports, production and holdings of small arms, and on national weapons legislation (...) (Article 3.e). The regional registers referred to are not the systematic records indispensable to the functioning of a tracing system, but are rather registers of a general nature.

Let us point out that the EU had introduced at the end of 2000 a proposed Plan of Action in the context of the preparation of the UN Conference on Small Arms and Light Weapons,⁴⁶ which foresees some interesting elements relating to traceability. Notable among them are:

- The reinforcement of the traceability of small arms, by negotiating during the following years, an international convention, which will generalize, in particular, marking and registration practices, according to harmonized and universally recognized systems (Article 27);
- The requirement at the national level to apply unique and reliable marking to small arms, and to keep records for a minimum of 50 years of the data necessary to subsequently trace illicit weapons (Articles 2. b and c), and covering production, stocks and transfers (Article 3.).

5.3.2 The Bamako Declaration

The “Bamako Declaration on an African Common Position on the Illicit Proliferation, Circulation and Trafficking of Small Arms and Light Weapons” was adopted on 1 December 2000, in preparation for the UN Conference on Small Arms and Light Weapons. Although this text served as a reference during the Conference, with respect to traceability it contains only recommendations to the member States:

- To put in place, where they do not exist, national coordination Agencies as well as the appropriate institutional infrastructure responsible notably for monitoring on all aspects of SALW proliferation, control, circulation, trafficking and reduction (Article 3.A. i);
- At the regional level, to implement, where they do not yet exist, mechanisms to coordinate and harmonize efforts to address the issues of proliferation, circulation of and trafficking in small arms and light weapons (Article 3.B.i);
- To encourage the codification and harmonization of legislation, especially with respect to marking, registration and controls for imports, exports and legal trade (Article 3.B.ii).

Furthermore, the African States have:

- Recognized that it was vital to improve the capacity of member States to identify illicit weapons (Article 2.vi);
- Urged the supplier States of weapons to apply mechanisms aimed at facilitating the identification of transfers of illicit weapons (Article 4.v);
- Requested the competent international organizations, such as Interpol, the World Customs Organization, and the UN Regional Centre for Peace and Disarmament in Africa, to play a more important role in the struggle against the proliferation, circulation and trafficking of SALW (Article 5.v).

5.3.3 The Code of Conduct for the Implementation of the ECOWAS Moratorium

The “Moratorium on the Implementation, Exportation and Manufacture of Small Arms and Light Weapons in West Africa” was signed on 31 October 1998 at Abuja by the 16 member States of the Economic Community of West African States (ECOWAS), and was extended for three

years in July 2001. In December 1999, the member States adopted a Code of conduct for the implementation of the Moratorium. It foresees that:

- the Executive Secretariat, with the assistance of the Programme for Coordination and Assistance on Security and Development in West Africa, shall develop an arms register as a confidence-building measure with the intention of developing an electronic database of all legitimate stocks of weapons, ammunition and components covered by the Moratorium (Article 6);
- The member States shall provide all necessary information to the arms register and database. The Executive Secretary shall include all this information in his annual report to the Heads of State and Government (Article 6).

5.3.4 Interpol Weapons and Explosives Tracking System (IWETS)

Interpol is an intergovernmental organization comprised of 178 members. Its role is to centralize information concerning international criminal activities gathered by the national bureaus of each of its member States. In 1987, Interpol created a system of identification for firearms and explosives called IWETS.⁴⁷ It provides for a standardized administrative procedure in the event of illicit weapons seizures by national police forces. This involves providing information about the weapons or explosives on specially-designed forms that are then submitted to Interpol. This information is then summarized and recorded in a centralized database where it can be compared with other information.

Despite being the only international database in existence to date, its scope of application and effectiveness are nevertheless limited. First of all, it concerns only weapons or explosives uncovered in the context of criminal investigations. However, in order to trace illicit weapons with a satisfactory degree of success, we need a system which registers all the transactions relative to small arms (including ammunition and explosives), whether legal or illicit (even if it is then decided to trace only those weapons that have become illicit). Secondly this inherent shortcoming is reinforced by the very minimal resources that IWETS disposes of, as only one person is responsible for coordinating the entire system.⁴⁸

Nevertheless, thanks to IWETS a great number of investigations into the origin of weapons are able to be carried out. Its database comprises a

firearms index that contains the names and addresses of all the weapons manufacturers in the world, as well as the descriptions of the models and an indication of their calibre and country of manufacture.⁴⁹

In conclusion, IWETS should be given substantially greater resources and should have a much wider scope of application (covering all SALW) in order to establish a proper tracing operation.⁵⁰ Nevertheless, it is an interesting mechanism to consider, and several of the mechanisms examined in section 5.2 called for collaboration with Interpol.

5.3.5 The Franco-Swiss Initiative

This is a more informal initiative, but one which could prove to have an important effect on the constitution of a broader international marking and tracing mechanism. This initiative is backed by the EU. This process recently led to the constitution of a group of ten States that are practically all represented in the UN Group of Governmental Experts on the Marking and Tracing of Small Arms. One of the objectives of this group of States is to provide support for and input into the work of the Group of Experts.

The “Franco-Swiss Initiative” consists of two documents introduced during the first and second sessions of the Preparatory Committee for the UN Conference on Small Arms and Light Weapons (March 2000 and January 2001),⁵¹ as well as a series of seminars intended to explain these initiatives to other countries.

The “Franco-Swiss Initiative” is a process rather than a fixed position, and as such its contents are subject to change. Nevertheless, we have listed the main points set forth in the aforementioned documents:

- All SALW are to be marked in an appropriate manner, and existing weapons that are not marked appropriately are to be marked or else promptly destroyed.
- Appropriate markings must be unique and must identify the manufacturing and importing countries;
- Appropriate marking must be financially feasible, based on a known technique, safe and reliable. A process must be established to permit technological developments to be continuously evaluated;
- Registration systems should be accurate, allowing the competent national bodies to collect and use precise information;

- States must make efforts to cooperate, and must respond quickly and accurately to requests for information from other States or from the UN, maintaining an appropriate level of confidentiality;
- An international consultative body is to be created, which would be in charge of advising States on technical issues related to marking, registration and tracing, in consultation with the industrial sector, research institutes and experts;
- Cooperation and international assistance are to be promoted, in order to ensure the widest possible participation of States in the process.

5.4 BUILDING A MECHANISM THAT IS BROADER IN SCOPE

Although the last ten years have seen the birth and growth of most of the mechanisms and initiatives with respect to tracing, we still lack a satisfactory mechanism with a global scope. The international community recognizes this problem, and has responded by appointing a UN Group of Experts in charge of studying the possible establishment of an international instrument to enable States to identify and trace in a timely and reliable manner all illicit SALW.

A comparison of the main mechanisms demonstrates that they often pursue the same objectives, but that their scope and application methods differ greatly. That being said, what is of interest now is:

- whether identifying synergies between these mechanisms would bring an “added value” to each of them;
- whether this interaction is possible from a legal point of view;
- whether there are other interesting ways to establish an effective global system.

These are really three relatively simple questions that we will try to answer in concluding this study.

5.4.1 The Interest in Looking for Synergies

There is no doubt that the different mechanisms would benefit from finding synergies with one another.

-
- a. From a geographical point of view, traceability cannot be truly effective as a tool to combat international trafficking, unless it is applied worldwide. Arms traffickers ignore regional borders—they are in fact quite ingenious in their efforts to find loopholes in the systems that attempt to thwart their activities, and tend to operate via the States or regions that have the most lax regulation. In spite of this, to date many States have not yet ratified any of the Conventions examined here, in some cases simply because they do not belong to a region that has sought access to such a Convention;
 - b. In view of the *weapons concerned*, traceability must cover all SALW, ammunition and explosives, given that they all have the potential to be misused. It is paradoxical that ammunition and explosives are the least regulated with respect to tracing, and yet they are probably the most strategic of the elements. This is certainly the case with explosives in the context of terrorism, just as it is the case with ammunition in conflict prevention (since firearms are usually abundant in areas of tension, acting on the supply of ammunition, which is perishable and difficult to move, seems to be more effective in the short term). Furthermore, we note that the field of application of the different mechanisms is disparate. The UN Programme of Action is the only mechanism that appears to cover all weapons, ammunition and explosives, but the issue of which weapons are covered has in fact not been completely resolved. Of the other mechanisms studied, we note that their fields of application are mutually exclusive: four of them concern only firearms (and these differ⁵² with respect to the kinds of firearms they cover), while the two others deal only with explosives and/or ammunition.⁵³ However, if the goal is to have synergies among the existing mechanisms, it is essential that their fields of application become more harmonized. If this harmonization is “top-down” (according to the narrowest definition) rather than “bottom-up”, then no weapons would be covered, as we have just seen. The answer is to level off the field by applying the widest coverage, which is politically complicated given that it implies renegotiating each mechanism;
 - c. Unfortunately, the situation is the same with respect to the *multitude of concrete aspects* relative to marking, national records and tracing operations. To take only one example, the State parties to the OAS Convention have difficulty registering imported weapons because of the very disparate types of markings they bear.⁵⁴ We therefore arrive at the same conclusion as in the preceding point: looking for synergies obviously makes sense, but in order to do so it is indispensable to have

a greater degree of harmonization of the many concrete aspects, so that the lowest common denominator represents something consistent.

5.4.2 Feasibility of the Synergies

It is theoretically possible to build synergies between two or even all of the different mechanisms if considerable work is first done to harmonize them. In practice, such a task would seem absurd, according to Professor Pierre Klein of the Centre de droit international at the Université Libre de Bruxelles. It would imply a daunting political task, consisting of convincing all States parties to each mechanism to adapt their regime to the regime of one or more different mechanisms. It also seems that there is no precedent whatsoever for the inter-regional harmonization of similar mechanisms.

5.4.3 Other Leads

The arguments above obviously do not suggest that the existing mechanisms are not useful. Pending the establishment of an effective global system, these mechanisms have allowed the participating States to set forth their positions and to seek consensus. They also represent a series of concrete steps forward and exemplary initiatives. In any case, the creation of a new worldwide mechanism that would entail bringing all States directly to the negotiating table is a far easier approach than redrafting and adapting each of the existing mechanisms. Moreover, this approach appears even more compelling in light of the fact that the traceability of SALW, ammunition and explosives is an intrinsically multilateral task.

One remaining question is whether the prior existence of legally-binding mechanisms is not an obstacle to the creation of a new regime. The answer is negative, as long as there are no contradictory obligations between the existing mechanisms and the new regime (for example, a ban on all types of marking in one regime, and the obligation to apply marking in another). In any case, if the international community finds it necessary and has the will to undertake it, it is always technically possible to abrogate a legally-binding mechanism,⁵⁵ or some of its articles.⁵⁶ It must be remembered that the aim is to conserve effort, especially by ensuring that the national register foreseen by one mechanism is truly compatible with the national register stipulated by another mechanism.

A further question concerns whether or not it would be appropriate to use the Vienna Protocol as a foundation on which to establish the globally applicable and effective mechanism we are seeking. The Vienna Protocol has the advantage of being a legally-binding mechanism that is global in scope. Moreover, being the result of lengthy international negotiations, it is an undeniably valuable source for comparing the different points of view surrounding this issue. However, the Protocol was drafted according to a different philosophy than that of the UN Programme of Action. The Protocol's aim is exclusively to fight transnational organized crime, while the Programme of Action has a much wider scope that also encompasses arms control and disarmament. The idea of amending the Protocol to build a binding instrument with a wider objective seems impracticable, given that this Protocol is supplementary to a Convention that is itself the result of other negotiations that have given rise to two additional protocols.⁵⁷ It therefore remains to be seen whether the Vienna Protocol could serve as a basis for the drafting of a different and more ambitious mechanism.

In this case, there is a danger that the new mechanism would probably be negotiated by the same national representatives who negotiated the Vienna Protocol. Since they mainly come from "law and order" circles, one may question whether they would be sufficiently attentive to the objectives of "disarmament and arms control" set forth in the UN Programme of Action. The fact that the same kind of difficulties were encountered during the negotiation of this Programme and of previous discussions⁵⁸ suggests that there is a good chance that they may not be. In addition, this community of negotiators of the Vienna Protocol may not be sufficiently open to the advances that are necessary for attaining an efficient international tracing system—particularly in the areas of registration, information exchange and scope (ammunition and explosives are not covered, and State-to-State transfers only partially so).

Let us end with two technical aspects that are useful to keep in mind. First of all, a Convention may very well contain a reservation clause for certain articles that are considered by a minority of States as being too ambitious, and that are less fundamental. In other words, the States are given the possibility to ratify the Convention, but at the same time to opt out (either definitively or for a certain period of time) of a certain article for which this option has been explicitly foreseen. This allows certain provisions to be retained that would otherwise be eliminated outright. At the same time, however, it is important that such an option not be misused, because

this may lead to the undesirable result whereby the least ambitious States hastily propose the inclusion of a reservation clause for a particularly important article.

Another similar technical possibility is that a Convention may contain certain supplementary protocols. As the issue of explosives proved to be a very sensitive topic during the Vienna Protocol negotiations, it is possible, for example, that the new Convention concern only firearms and ammunition, and that it be accompanied by a protocol that specifically addresses explosives.

Notes

- ¹ The authors would especially like to thank Mr. Wittebolle, Director of the “Institut Belge de l’Emballage”, for his explanations concerning the transport of dangerous goods; and Professor Pierre Klein, of the “Centre de droit international” at the “Université Libre de Bruxelles”, for his legal explanations.
- ² The owner of an illicit weapon is by definition not registered.
- ³ United Nations Document A/RES/55/255, 8 June 2001.
- ⁴ United Nations Document A/CONF.192/15—July 2001.
- ⁵ Adopted at Montreal, 1 March 1991.
- ⁶ United Nations, *Recommendations on the Transport of Dangerous Goods*, ST/SG/AC10/1/rev.12, twelfth revised edition, August 2001.
- ⁷ Adopted at Washington, 13 November 1997.
- ⁸ Adopted at Blantyre, 14 August 2001.
- ⁹ OSCE Document FSC.DOC/1/00, 24 November 2000.
- ¹⁰ Given that 99% of illicit weapons were initially part of the legal circuit (*Small Arms Survey* 2001), all weapons must be traceable and therefore they must all be included in the system.
- ¹¹ This allows: (i) weapons possessed by police and security forces to be systematically and gradually included during the routine administration of stockpiles, and (ii) sufficient time to civilians who have not yet complied with the new marking and registration rules to do so.
- ¹² The Vienna Protocol is supplementary to this Convention.
- ¹³ As defined in 1997 in the *Report of the UN Group of Governmental Experts*, United Nations Document A/52/298.

- ¹⁴ “Strictly speaking” here means “excluding ammunition and explosives”—which are also considered as small arms by the United Nations.
- ¹⁵ The interpretation of this article is sometimes disputed, because during the negotiations, certain States initially wanted State-to-State transfers to be completely excluded from the field of application. Ultimately, a somewhat ambiguous formulation was deliberately adopted, which the large majority of States interpret as including State-to-State transfers (except when national security is an issue), and which a minority of States still run the risk of interpreting as excluding State-to-State transfers.
- ¹⁶ See United Nations document A/C.1/56/L.47, 19 October 2001.
- ¹⁷ As the question of the definition was very much disputed by a minority of countries, including the US, it was left out of the negotiations.
- ¹⁸ We have used the term “small arms” to designate the “small arms and light weapons” referred to in the original English version of the text of the UN Programme of Action. As such, it is to be understood in the broad sense as including light weapons.
- ¹⁹ Let us point out that it is also applied by countries that have not yet ratified it, such as Belgium.
- ²⁰ This description is a half-page long and is therefore not included here. Note that the contents of the so-called technical appendix may be modified according to a procedure clearly defined in the Convention. It is worth mentioning also that Swiss legislation provides for the marking of all civilian explosives.
- ²¹ The definition of “barrelled weapons” excludes rocket launchers and missile systems.
- ²² According to the definition of antique used in the national legislation.
- ²³ In this text, we shall use “small arms” and “small arms and light weapons” indiscriminately.
- ²⁴ This can be noted: (i) in the enumeration that follows the definition and which includes, notably, rifles and carbines, and (ii) during exchanges of information, certain States communicate information on hunting weapons, for example.
- ²⁵ For more details, see the GRIP publications mentioned in the bibliography.
- ²⁶ Usually carried out by stamping, engraving or casting.
- ²⁷ The idea is to avoid that the marking be obliterated by the simple replacement of the only marked element.

- ²⁸ Or at least difficult or impossible to erase without compromising the proper functioning of the weapon. This is obtained by applying the marking to essential but fragile parts, or in an area that is inaccessible once the manufacturing process is complete (such as the inside of the barrel).
- ²⁹ Marking by laser fulfils these conditions and numerous North-American manufacturers have taken it upon themselves to use this technique to inscribe the legally mandatory phrases (for more information, see the GRIP publications mentioned in the bibliography and consult the site www.controllaser.com).
- ³⁰ In other words, each element of ammunition or explosive from the same batch bears the same number (unlike firearms), which always includes the mention of the manufacturer, country and year. For ammunition, all this information can easily be applied to the base of the case using the inexpensive laser marking technique (it should be noted that the case can be reloaded, but this is not of interest for large-scale trafficking). For explosives, the powder can also be marked by means of chemical tracers. For further details, see the GRIP publications mentioned in the bibliography.
- ³¹ Some countries, like China, already use symbols, and have thus obtained the right to continue this practice. This considerably complicates the operations of recording transactions and of exchanging the information necessary for tracing. Through such measures, these States guarantee themselves the exclusive right to carry out tracing within their borders.
- ³² This article was influenced by article 8.1.a of the Vienna Protocol, which stipulates that the serial number does not necessarily have to be legible by all the States.
- ³³ Note that for the sake of readability, this section does not reflect all the details of the complex marking provisions of the Convention, and limits itself to the most important aspects only.
- ³⁴ This arduous task is however unnecessary if, in addition to national records, there is an international register containing all the national data. Such record-keeping would allow the immediate identification of all registered owners.
- ³⁵ Let us note, however, that in this case the provision of the Protocol aims only to encourage the industry to develop measures against obliteration, and not to set minimum obligatory standards.
- ³⁶ This timeframe is quite logical—in the first place, it represents the minimal period during which the firearms, ammunition or explosives

are considered dangerous, and in the second, it must be compared with definitions of firearms that do not exclude antique weapons on the basis of duration.

- 37 Let us point out that it is also possible to trace the different components of the packaging (for example, the rolls used to manufacture a carton)—which must correspond to strict quality standards. Should the quality be sub-standard, those responsible can then be identified.
- 38 According to information provided by Mr. Maxence Wittebolle, Technical Director of the Belgian Packaging Institute. The three institutes in question are those of Belgium, Austria and the Netherlands.
- 39 The description of the Protocol's contents in this area is given in section 5.2 and not repeated in section 5.3.
- 40 This is indispensable given that arms traffickers usually try to cover their tracks by moving through many countries, and seek to carry out their activities precisely where laws are non-existent or ineffective.
- 41 Without prejudice to paragraph 13 of article 18 of the Convention, which foresees that if a State party has a region or territory in which a different legal system applies, it may designate a distinct central authority that will have the same function for the region or territory in question.
- 42 Without prejudice to article 27 of the Convention, which foresees measures that aim to improve cooperation between law enforcement agencies, or to article 28 in which the States parties consider developing their capacity to analyse organized criminal activities and to evaluate the implementation of their policies aimed at combatting organized crime.
- 43 Interpol is the abbreviation for the International Criminal Police Organization.
- 44 This somewhat strange formulation is taken directly from the original.
- 45 Document referenced 1999/34/CSEP in the *Official Journal of the EU* (L). On 12 July 2002, the Council abrogated the latter with a new Document with the same terms but including ammunition (Ref. 2002/589/CSEP in the *Official Journal*, 19.7.2002).
- 46 United Nations Document A/CONF.192/PC/21, 28 December 2000.
- 47 IWETS is the acronym for "Interpol Weapons and Explosives Tracking System".
- 48 In certain countries such as Great Britain, one person covers arms trafficking at the national level.

- 49 Speech by Mr. Koffi Adjoumani Kouman, Sub-regional Interpol Bureau for West and Central Africa, African Conference relative to the implementation of the United Nations Programme of Action, Pretoria, 18 March 2002.
- 50 Reminder: the tracing operation can function only if conditions concerning marking and national registration have been adequately met in each of the States.
- 51 “Discussion paper—Contribution to the implementation of an international plan of action for the 2001 Conference: marking, identification and control of small arms and light weapons”, Note verbale introduced by France and Switzerland, dated 17 March 2000 (Document A/CONF.192/PC/7), and “Working Paper on Establishing a Tracing Mechanism (...)”, introduced by France and Switzerland on 10 January 2001 (Document A/CONF.192/PC/25).
- 52 These differences occur in the definitions of the weapons, but also in the fact that certain sub-categories are sometimes not included (e.g. the OSCE Document does not appear to address civilian weapons), or they occur in the types of transfer covered (e.g. the Vienna Protocol does not cover all State-to-State transfers).
- 53 See the comparison tables at the end of this chapter.
- 54 Source: our interview with a Mexican official.
- 55 Let us recall that to date, the OAS Convention is the only legally-binding mechanism that has entered into force.
- 56 This is more plausible. Most of the mechanisms discussed concern not only traceability, but also other aspects related to small arms.
- 57 The United Nations Convention against Transnational Organized Crime is supplemented by three protocols: (i) against the illicit trafficking in firearms, (ii) against trafficking in persons, and (iii) against the smuggling of migrants (see http://www.odccp.org/crime_cicp_signatures.html).
- 58 Geraldine O’Callaghan and Suzannah L. Dyer, “One Size Fits All?”, Basic Report 99/2, p. 27.

BIBLIOGRAPHY

- Bamako Declaration on an African Common Position on the Illicit Proliferation, Circulation and Trafficking of Small Arms and Light Weapons, Bamako, 1 December, 2000.
- Code of conduct for the implementation of the Moratorium on Importation, Exportation and Manufacture of Small Arms and Light Weapons, Lomé, 10 December 1999.
- “Contribution to the realization of an international plan of action in the context of the 2001 Conference: marking, identification, and control of small arms and light weapons”, Appendix to the Note verbale of France and Switzerland, New York, 17 March 2000, Document A/CONF.192/PC/7.
- Convention of the Organization of American States against the Illicit Trafficking in Firearms, Washington, 13 November 1997, Document O.E.A. A-63.
- Convention on the Marking of Plastic Explosives, Montreal, 1 March 1991.
- Council Directive 94/55/EC of 21 November 1994 on the approximation of the laws of the Member States with regard to the transport of dangerous goods by road.
- European Agreement concerning the Transport of Dangerous Goods by Inland Waterways (A.D.N.), 25 May 2000.
- European Agreement for the Transport of Dangerous Goods by Road (A.D.R.), Geneva, 30 September 1957. Modified by the Protocol, New York, 21 August 1975.
- Joint Action adopted by the Council on the basis of article J.3 of the Treaty on European Union on the EU’s contribution to combating the destabilizing accumulation and spread of small arms and light weapons and repealing Joint Action 1999/34/CFSP, Document 2002/589/CFSP in the Official Journal, 19 July 2002).
- OSCE Document on Small Arms and Light Weapons, Vienna, 24 November 2000, OSCE Document FSC.DOC/1/00.
- Plan of Action to Prevent, Combat and Eradicate the Illicit Trade in Small Arms and Light Weapons in All its Aspects, Note verbale from France

in its capacity as President of the European Union, New York, 28 December 2000, UN Document A/CONF.192/PC/21.

Programme of Action to Prevent, Combat and Eradicate the Illicit Trade in Small Arms and Light Weapons in All its Aspects, New York, 21 July 2001, UN Document A/CONF.192/15.

Protocol Against the Illicit Manufacturing of and Trafficking in Firearms, Their Parts, Components and Ammunition, supplementing the United Nations Convention against Transnational Organized Crime, Vienna, 8 June 2001, UN Document A/RES/55/255.

Protocol on the Control of Firearms, Ammunition and Other Related Materials, of the Southern African Development Community, Blantyre, 14 August 2001, SADC Document.

Recommendations on the Transport of Dangerous Goods: Model Regulations, UNECE, twelfth revised edition, August 2001, Document ST/SG/AC10/1/rev.12.

Working paper by Switzerland and France on establishing a tracing mechanism to prevent and reduce excessive and destabilizing accumulation and transfer of small arms and light weapons, New York, 10 January 2001, UN Document A/CONF.192/PC/25.

Table 1: Scope of the Seven Principal International Instruments for the Traceability of SALW¹

Characteristics	Vienna Protocol	UN Programme of Action	Convention on the Marking of Plastic Explosives	International regulations on the transport of dangerous goods	OAS Convention	SADC Protocol	OSCE Document	Desirable system
Binding?	Legally	Politically. Foresees a feasibility study of an international tracing instrument	Legally	Legally	Legally	Legally	Politically	Legally
Geographical scope	Global	Global	Global	Global for UN model regulations; EU or European in the broad sense for others	Members of the Organization of American States	Members of the Southern African Development Community	Members of the Organization for Security and Cooperation in Europe	Global

¹ SALW is the abbreviation for "small arms and light weapons".

Number of States concerned	All Member States of the UN	All Member States of the UN	All Member States of the UN	All States for the UN model regulations; 40 European countries/the EU for the directive on transport by road; national initiatives	35	14	55	All States
Date of signature	31 May 2001	21 July 2001	1 March 1991	UN model	13 November 1997	14 August 2001	24 November 2000	On the occasion of the 2006 UN Conference on Small Arms
Date of entry into force	Pending	As above	21 June 1998	As above	1 July 1998	Pending	As above	---
Number of ratifications (as per 20/11/2002)	3 ratifications and 46 signatures ²	Adopted by consensus	At least 35 ratifications	40 for the European Agreement. No application for the others	16 ratifications and 33 signatures	4 ratifications	-- (no application)	-- (no application)

² The number of ratifications required for entry into force is 40. Another condition is that the Convention against Transnational Organized Crime is in force (143 countries have signed and 25 have ratified this Convention). A State wishing to ratify the Protocol must have ratified the Convention.

Table 1 (continued)

Characteristics	Vienna Protocol	UN Programme of Action	Convention on the Marking of Plastic Explosives	International regulations on the transport of dangerous goods	OAS Convention	SADC Protocol	OSCE Document	Desirable system
Concerns all small arms and light weapons in the strict sense? ³	Yes (with the exception of weapons manufactured prior to 1899)	It is understood as doing so ⁴	No (does not concern firearms)	No (does not concern firearms)	Yes (with the exception of weapons manufactured prior to 1901)	Yes (except for antique weapons)	Yes (although it is ambiguous as far as non-military weapons are concerned)	Yes (except for antique weapons)
Concerns ammunition?	Not in the area of traceability	It is understood as doing so, but this question is disputed	No	Yes	Not in the area of traceability	Not in the area of traceability	Not in the area of traceability	Yes

³ The issue here is the definition given in the Report of the Group of Governmental Experts of 1997 (Doc. A/52/298), but does not include ammunition and explosives.

⁴ This question was not dealt with during said UN Conference because it was likely to lead to interminable disputes.

Concerns explosives?	No	It is understood as doing so, but this question is disputed	Yes (plastic and sheet explosives)	Yes	No in a way that binds the States	Not in the area of traceability	Not in the area of traceability	Yes
General objective of the mechanism	Objective limited to combatting transnational organized crime	To prevent, combat and eradicate the illicit trade in SALW in all its aspects	Detection of explosives and not individual tracing	Includes a number of regulations, the principle objective being that of public safety	To prevent, combat and eradicate trafficking	To prevent, combat and eradicate illicit manufacturing and trafficking, and to counter proliferation	To cooperate to counter proliferation and guarantee global security	To prevent, combat and eradicate the illicit trade in SALW in all its aspects

Table compiled by Michel Wéry and Ilhan Berkol, GRIP, May 2002.

Table 2: Comparison of Marking Standards for SALW

Characteristics of the marking	Vienna Protocol	UN Programme of Action	Convention on the Marking of Plastic Explosives	International regulations on the transport of dangerous goods	OAS Convention	SADC Protocol	OSCE Document	Desirable system
Firearms, ammunition and explosives concerned	Firearms only	Small arms and light weapons. According to the definition of the Group of Experts, they include ammunition and explosives	Explosives only (plastic and sheet explosives)	Concerns the packaging of ammunition and explosives only	Firearms. Explosives must be marked "if possible"	Firearms only	Firearms only (ambiguity exists as to whether civilian weapons are included)	All small arms and light weapons, as defined by the UN Group of Experts
Includes a unique serial number, the identification of the manufacturer and the country	Yes	Yes (but it does not specify that the serial number must be unique)	No (tracers are incorporated to allow the presence of explosives to be better detected)	Yes for the packaging, but not for the ammunition or explosives themselves	Yes (but it does not specify that the serial number must be unique)	Yes	Yes	Yes

Includes the year of manufacture	No	No	No	Yes for the packaging	Not specified	Not specified	Yes	Yes
Durability of the marking	States encourage the industry to develop measures to prevent alteration	Not specified	Yes	The packaging bears a marking that cannot be altered inconspicuously. The contents, which are not marked, can be transferred elsewhere, however	Not specified	Not specified	Markings should be permanent	Classical marking combined with a security marking (difficult to alter) for newly manufactured weapons
Legibility	Some States may use simple geometric symbols they alone can read	Not specified	Only by the competent services	Common standards that foresee, notably, the use of the alphanumeric language	Not specified	Not specified	Not specified	Use of alphanumeric language exclusively

Table 2 (continued)

Characteristics of the marking	Vienna Protocol	UN Programme of Action	Convention on the Marking of Plastic Explosives	International regulations on the transport of dangerous goods	OAS Convention	SADC Protocol	OSCE Document	Desirable system
Parts on which the marking is applied	Not specified	Not specified	Applied to the powder	Only to the packaging	Not specified	On the barrel, the frame and, if possible, on the slide	Not specified	On a maximum number of the important parts (to be approved on a case-by-case basis by a technical committee)
Marking upon import	Identification of the importing country and of the year, or application of a unique serial number if none already exists	Not specified	No	No	Imported firearms must be marked so as to permit the name and address of the importer to be identified	Yes if there is not yet a unique number. Applicable to the barrel, frame and if possible to the slide	No	Identification of the importing country and of the year, or application of a unique serial number if none already exists

Marking of existing weapons	Unique marking that identifies the country during the transfer of the State's stockpiles to the civilian market	States ensure the prevention of the stockpiling, transfer and possession of weapons without adequate markings	Destruction, consumption or marking of existing explosives: within 15 years when they are under the strict control of the States, and within 3 years for the others	The packaging of existing ammunition and explosives is subject to the same rules as new ammunition and explosives	Weapons confiscated and put to official use must be appropriately marked	Not specified	States mark unmarked weapons discovered in the routine management of their stocks	Marking of all firearms within 10 years
Other		States undertake to exchange information on their marking systems	Technical assistance, and information exchange on marking techniques	The marking contains other information, such as the weight of the contents, and the States issuing the certificate authorizing the transport			Development of common standards; marking of weapons manufactured outside the territory if possible; exchange of information on national marking systems	

Table compiled by Michel Wéry and Ilhan Berkol, GRIP, May 2002.

Table 3: Comparison of the Standards for Record-Keeping Necessary to Trace SALW

Characteristics of the record-keeping	Vienna Protocol	UN Programme of Action	Convention on the Marking of Plastic Explosives	International regulations on the transport of dangerous goods	OAS Convention	SADC Protocol	OSCE Document	Desirable system
Conservation of the data in each State	Each State ensures the information is conserved	States ensure that the records are organized and maintained to permit the authorities to find precise information	Contains no provisions for the recording of data	In Europe, records are kept by Verification Institutes, which must transmit any information requested by the authorities. The producer is also under the obligation to conserve the data	The State Parties ensure the conservation of the information	States carry out the centralized recording of weapons held by civilians; maintain comprehensive national inventories of the state-owned weapons; and establish national databases to facilitate the exchange of information	States ensure that the records are kept and conserved	States establish national centralized registers, which are closely linked to the national point of contact on small arms (see the section "data exchange")
Regional or sub-regional registers	No	No		The Verification Institutes of three European countries have undertaken steps among themselves and with the EU to create a European databank	No, but a regional database is being established by the UN Regional Centre at Lima	States endeavor to compare in a coordinated manner their national procedures for the establishment and maintenance of electronic databases	States establish norms, principles and measures for the records, inspired by the OSCE security concept, and acting in concert with other international authorities	Harmonization of norms and practices. The regional databases are useful if an international database is not established

Firearms, ammunition and/or other explosives concerned?	Firearms, and if possible their parts, components and ammunition	The document does not contain any precise definition of small arms. But according to the UN, they include SAIW, ammunition and explosives	Concerns the packaging of all the explosives and ammunition	Firearms	Firearms in the case of civilians, and firearms, ammunition and other related materials for State organizations	Firearms held by the State, manufacturers, exporters and importers established on the territory	Firearms, ammunition and explosives
Information to be registered	Markings, and in the case of international transactions: dates relative to licenses and permits; exporting, importing and transit countries; the final recipient and the description and quantity of the articles	"Complete and exact registers" concerning the manufacture, possession and transfer	All the marking data (which is very detailed) and all the documents relative to controls during transport	The information necessary to trace and identify illicit firearms	"Complete national inventories", as well as conservation of markings	"Detailed and precise registers (...) with a view to improving traceability"	Data foreseen by the Vienna Protocol, plus: brokers and transport services, the identification of the seller and buyer, and the date the data was recorded. All of this presented in an internationally standardized format

Table 3 (continued)

Characteristics of the record-keeping	Vienna Protocol	UN Programme of Action	Convention on the Marking of Plastic Explosives	International regulations on the transport of dangerous goods	OAS Convention	SADC Protocol	OSCE Document	Desirable system
Duration of data conservation	At least ten years	As long as possible		As long as the type of packaging concerned is used. The information is then filed	For a reasonable period of time	Not specified ("the databases are maintained")	As long as possible	For as long as the weapons, ammunition and explosives concerned do not fall in the antique weapons category
Standards of efficiency for processing information	No	So as to be able to rapidly find and analyze precise information		Not specified	So that States are able to meet their obligations concerning exchange of information and mutual assistance	National electronic databases	States adopt and apply national control measures for the registers	Electronic databases which permit the rapid and precise response to requests for information
Standards for protecting the data from destruction	No	No		Not specified	No	No	Not specified (but the document foresees control measures)	Must be protected from destruction, spying and pirating activities

Other						States improve the capacity of the police, customs, coast guards, armed forces and legal representatives to use the system	States improve the capacity of the police, customs, coast guards, armed forces and legal representatives to use the system
--------------	--	--	--	--	--	--	--

Table compiled by Michel Wéry and Ilhan Berkol, GRIP, May 2002.

Table 4: Comparison of the Standards for Exchange of Data Necessary to Trace SALW

Characteristics of the exchange of data necessary for the tracing	Vienna Protocol	UN Programme of Action	Convention on the Marking of Plastic Explosives	International regulations on the transport of dangerous goods	OAS Convention	SADC Protocol	OSCE Document	Desirable system
Firearms, ammunition and explosives concerned	Firearms (and if possible their parts, components and ammunition) that may have been illegally traded by a transnational organized group	Illicit small arms and light weapons. According to the definition of the Group of Experts, they include ammunition and explosives	Contains no provisions relative to the exchange of information	There is no institutionalized exchange of data, but controls are under development. The use of electronic chips is being developed that will permit packages to be localized at any time by radio transmission.	Firearms, ammunition, explosives and other related materials that may have been illicitly manufactured or traded ¹	Firearms, ammunition and other related materials illicitly held, manufactured or traded (especially at the stage of prevention)	Illegal small arms (ambiguity concerning whether civilian weapons are included or not in the definition)	Illicit small arms and light weapons (SALW as defined by the UN Group of Experts)
Method of cooperation	States cooperate in tracing operations	States strengthen their capacity to cooperate in tracing operations			States cooperate bilaterally, regionally and internationally, especially in tracing	States establish appropriate mechanisms to cooperate among themselves and with international organizations like Interpol	States cooperate among themselves as well as with Interpol to localize illegal weapons and during investigations	States cooperate among themselves as well as with Interpol and any other international tracing structure

¹ Let us point out, however, that ammunition is difficult to trace if it has not been marked and registered.

National point of contact	Every States appoints a unique point of contact in charge of ensuring the liaison with the other States parties	States create or appoint a national point of contact in charge of the liaison with other States			States identify a unique point of contact that acts as a link with the States parties	States establish a national point of contact for exchange of information aimed at combating cross-border trafficking	A list of national points of contact will be established and kept up to date	States create or appoint a national point of contact in charge of the liaison with the other States
Regional and international exchange of information	No	States create or appoint within the sub-regional and regional organizations, points of contact to serve as a liaison for questions related to the UN Programme of Action			The point of contact also acts as a link with the Consultative Committee for the implementation of the Convention	No	No	At the very least, a simple International Agency, dependent on the UN, coordinates and centralizes the tracing operations. If this proves impossible in the short term, regional coordination is a useful initial stage.

Table 4 (continued)

Characteristics of the exchange of data necessary for the tracing	Vienna Protocol	UN Programme of Action	Convention on the Marking of Plastic Explosives	International regulations on the transport of dangerous goods	OAS Convention	SADC Protocol	OSCE Document	Desirable system
Quality of the exchange of data (rapidity, precision...)	States respond rapidly, to the best of their ability, to requests for help	Rapid and reliable tracing			To provide a rapid and precise response to requests	Establish direct communication systems to facilitate the rapid and free flow of information (this article is general and is not intended for tracing alone)	Communicate any pertinent information to the authorities in charge of an investigation	Rapid, precise, comprehensive and standardized exchange
Confidentiality	States guarantee the confidentiality of the information received, and in principle respect all restrictions on use if they are asked to do so	Not specified			States guarantee confidentiality if the supplier State of the information requests it	Not specified	Not specified particularly for tracing operations	Yes, as long as there are no investigations or legal proceedings

Crosscheck- ing of infor- mation useful in the struggle against traf- ficking in gen- eral	States exchange information concerning the routes customarily used by criminal groups	States voluntarily communicate information to the competent regional and international organizations, especially concerning the routes used by traffickers. States also strengthen their cooperation with Interpol			States exchange information on the routes customarily used by traffickers in arms, ammunition and explosives	No (but cooperation with Interpol)	Pooling of information concerning the seizure of illicit weapons while respecting confidentiality	The International Agency mentioned above cross-checks information to become more familiar with the routes customarily used by traffickers
Other					States cooperate among themselves and with the appropriate international organizations to ensure that their personnel is appropriately trained in all aspects concerning traceability	States provide mutual legal assistance for the detection of violations, the identification or tracing of suspects, etc.		

Table compiled by Michel Wéry and Ilhan Berkol, GRIP, May 2002.

